

Interior Space

Space is a prime ingredient in the designer's palette and the quintessential element in interior design. Through the volume of space we not only move, we see forms, hear sounds, feel gentle breezes and the warmth of the sun, and smell the fragrances of flowers in bloom. Space inherits the sensual and aesthetic characteristics of the elements in its field.

Space is not a material substance like stone or wood. It is an inherently formless and diffuse vapor. Universal space has no definition. Once an element is placed in its field, however, a visual relationship is established. As other elements are introduced into the field, multiple relationships are established between the space and the elements as well as among the elements themselves. Space is thus formed by our perception of these relationships.

SPACE

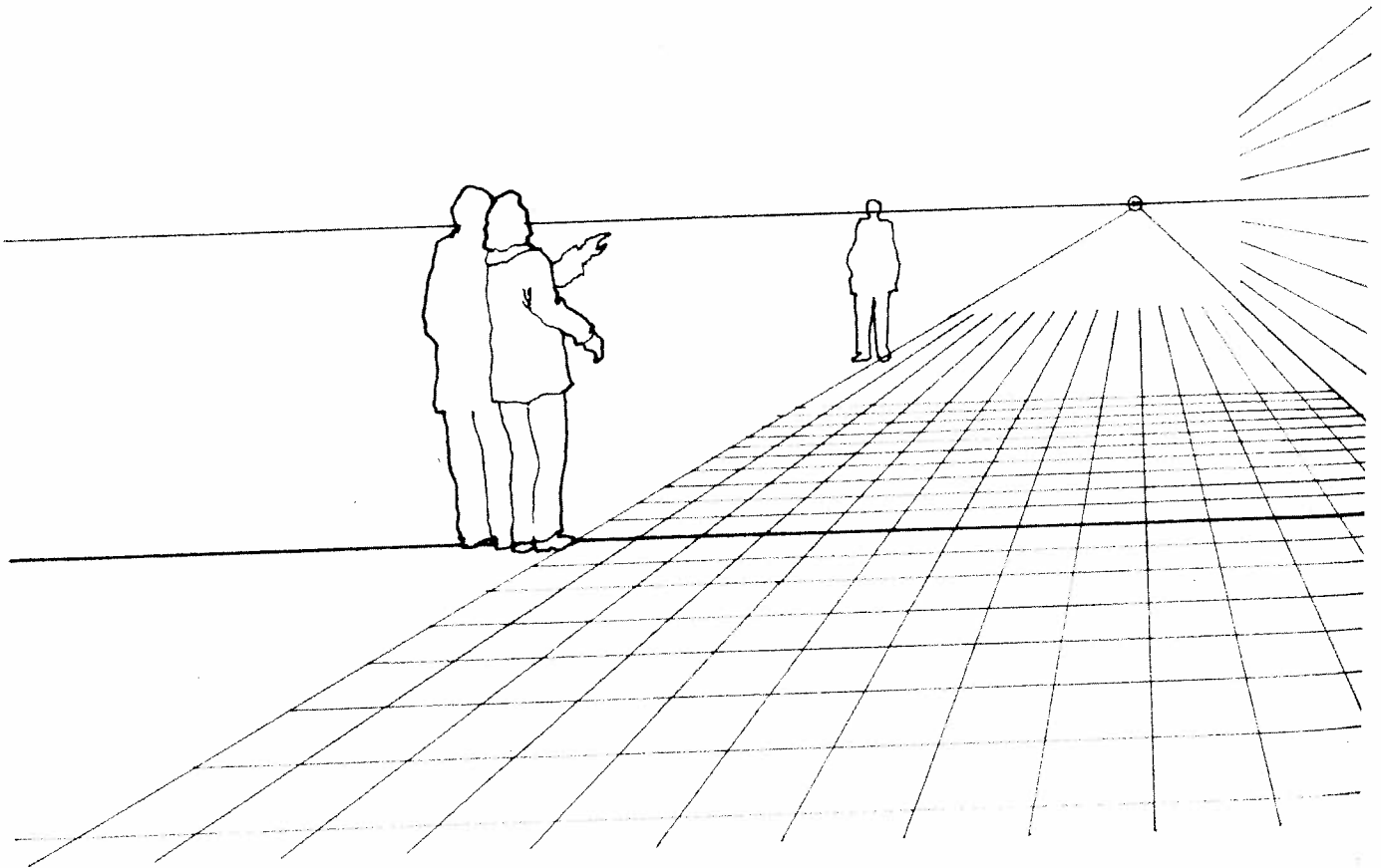

The geometric elements—point, line, plane, and volume—can be arranged to articulate and define space. In architecture, these fundamental elements become linear columns and beams and planar walls, floors, and roofs.

- A column marks a point in space and makes it visible in three dimensions.
- Two columns define a spatial membrane through which we can pass.
- Supporting a beam, the columns delineate the edges of a transparent plane.
- A wall, an opaque plane, marks off a portion of amorphous space and separates here from there.
- A floor defines a field of space with territorial boundaries.
- A roof provides shelter for the volume of space beneath it.

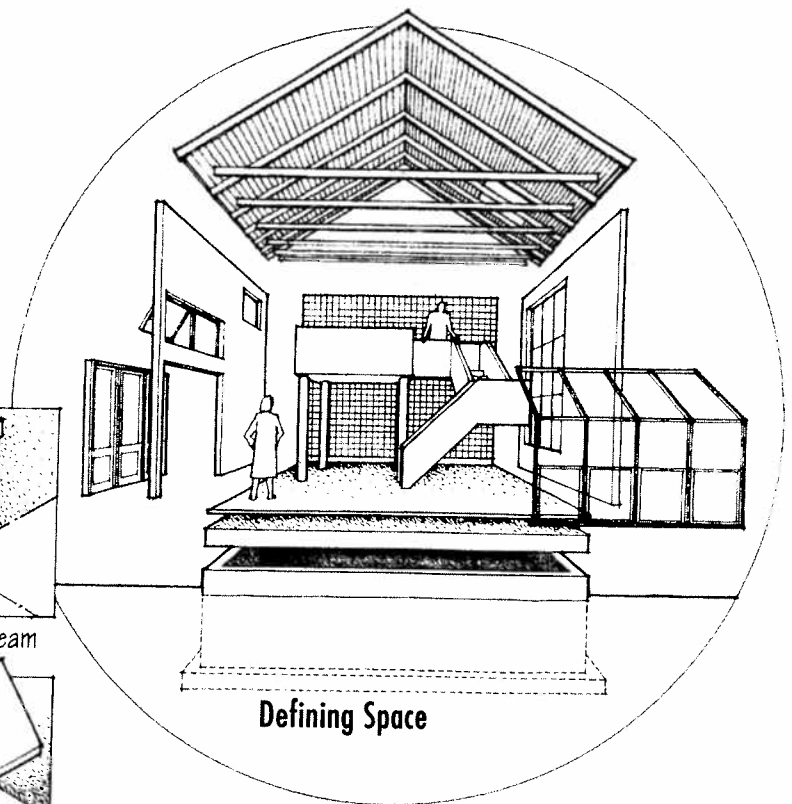
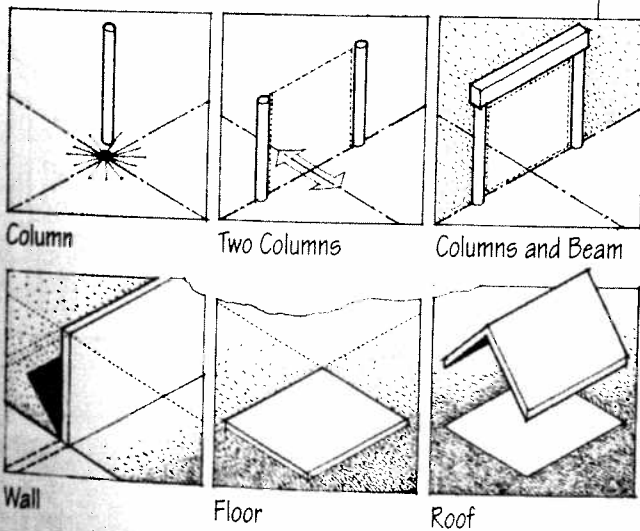

In architectural design, these elements are organized to give a building form, differentiate between inside and outside, and define the boundaries of interior space.

EXTERIOR SPACE

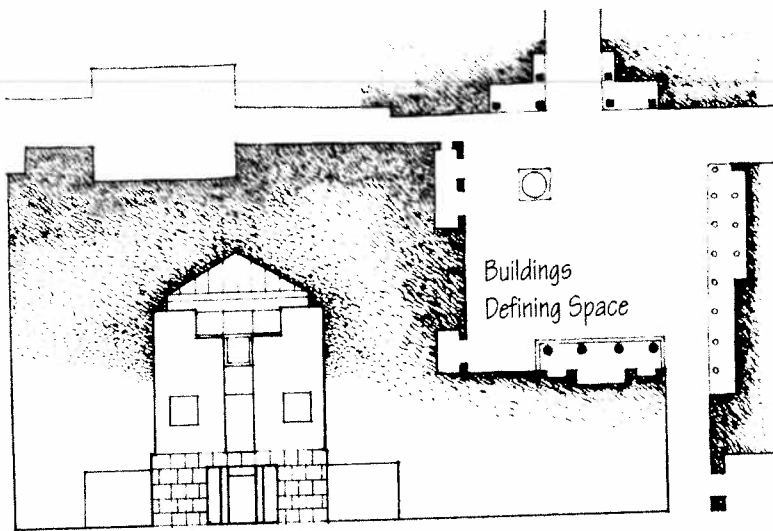

A Building in Space

A building's form, scale, and spatial organization are the designer's response to a number of conditions—functional planning requirements, technological aspects of structure and construction, economic realities, expressive qualities of image and style. In addition, the architecture of a building should address the physical context of its site and the exterior space.

A building can be related to its site in several ways. It can merge with its setting or dominate it. It can surround and capture a portion of exterior space. One of its faces can be made to address a feature of its site or define an edge of exterior space. In each case, due consideration should be given to the potential relationship between interior and exterior space, as defined by the nature of a building's exterior walls.

Buildings

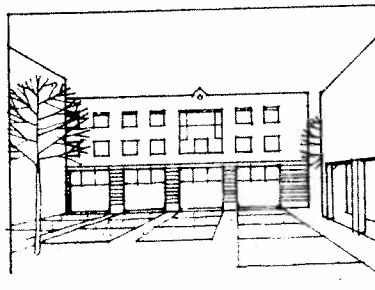
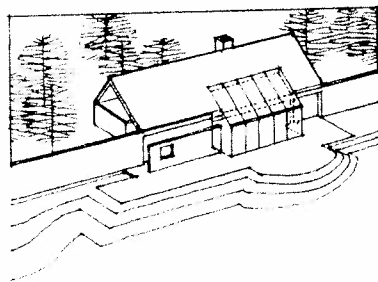
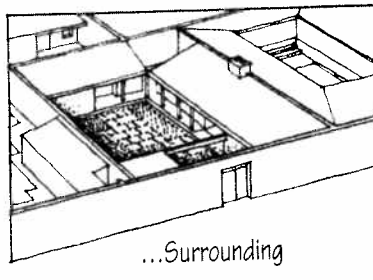
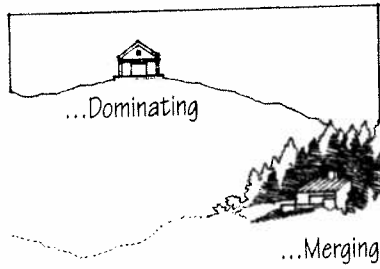

...Fronting

...Defining an Edge

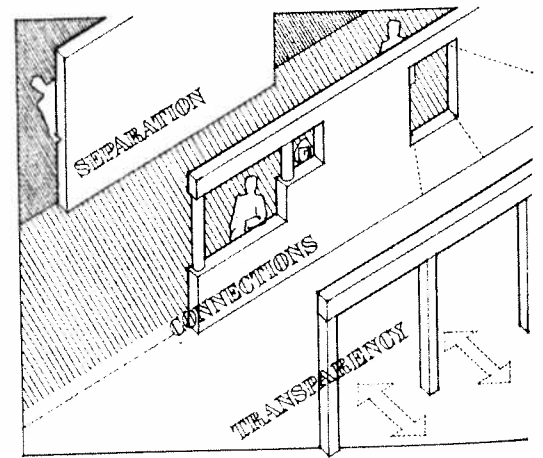

Exterior Walls

A building's exterior walls constitute the interface between our interior and exterior environments. In defining both interior and exterior space, they determine the character of each. They may be thick and heavy and express a clear distinction between a controlled interior environment and the exterior space from which it is isolated. They may be thin, or even transparent, and attempt to merge inside and outside.

Windows and doorways, the openings that penetrate a building's exterior walls, are the spatial transitions between exterior and interior space. Their scale, character, and composition often tell us something about the nature of the interior spaces that lie between them.

Special transitional spaces, belonging to both the outside world and the inside, can be used to mediate between the two environments. A familiar example in residential architecture is the porch. Cultural and climatic variations of this theme include the veranda, lanai, and arcaded gallery.

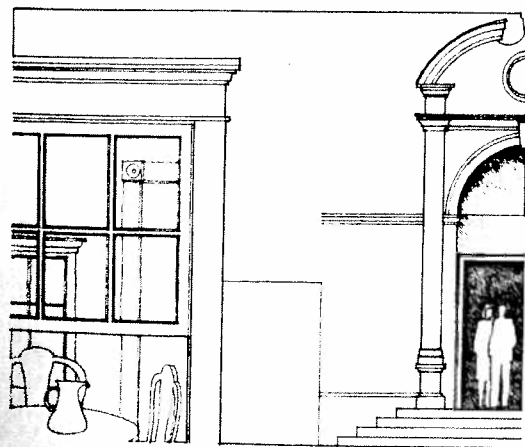
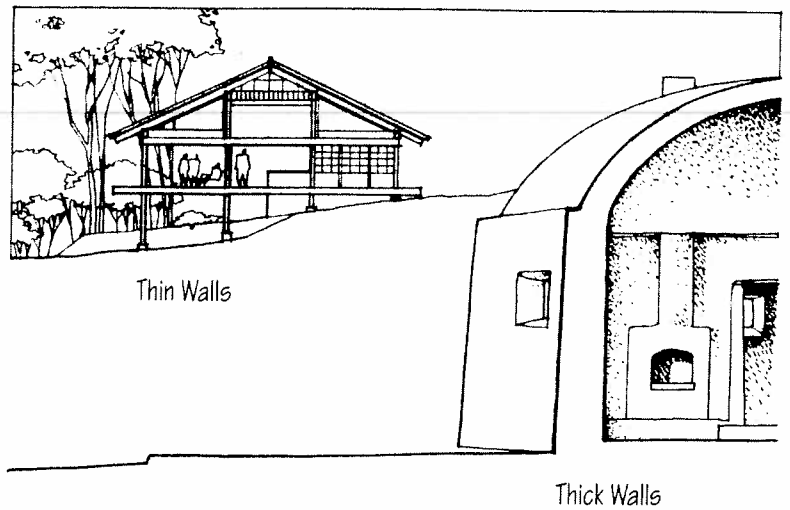

Spatial Transitions

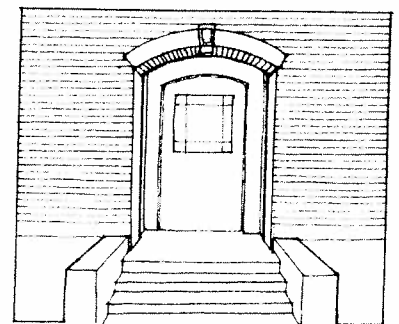
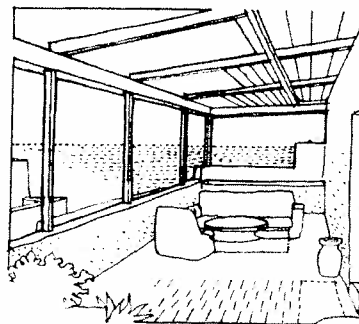
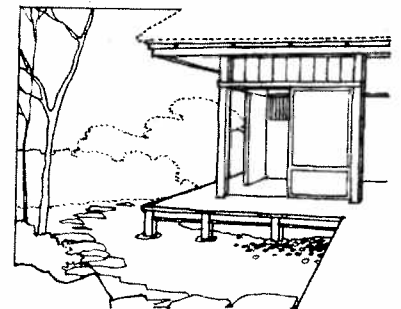
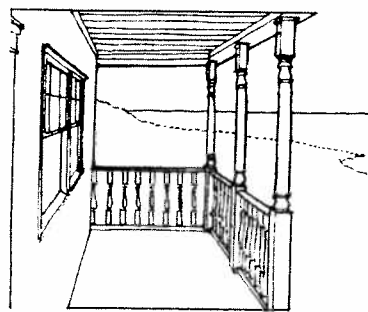

INTERIOR SPACE

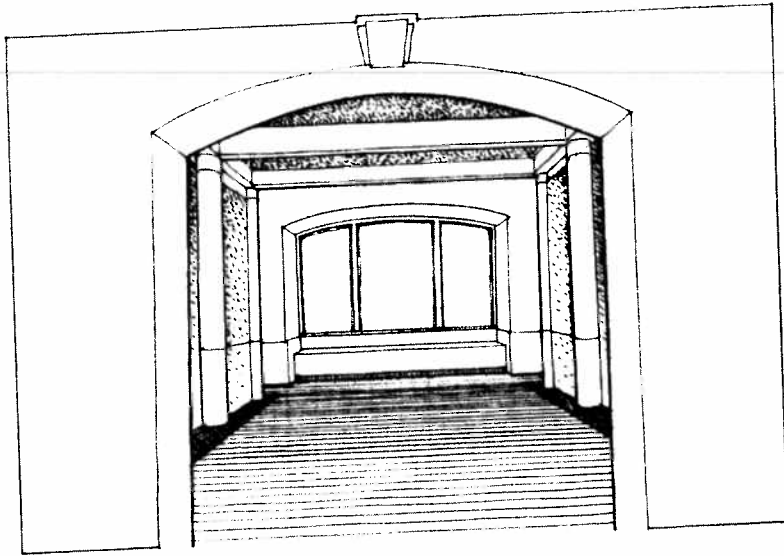

Entrances mark the transition from here to there.

Upon entering a building, we sense shelter and enclosure. This perception is due to the bounding floor, walls, and ceiling planes of interior space. These are the architectural elements that define the physical limits of rooms. They enclose space, articulate its boundaries, and separate it from adjoining interior spaces and the outside.

Floors, walls, and ceilings do more than mark off a simple quantity of space. Their form, configuration, and pattern of window and door openings also imbue the defined space with certain spatial or architectural qualities. We use terms such as *grand hall*, *loft space*, *sun room*, and *alcove* not simply to describe how large or small a space is but also to characterize its scale and proportion, its quality of light, the nature of its enclosing surfaces, and how it relates to adjacent spaces.

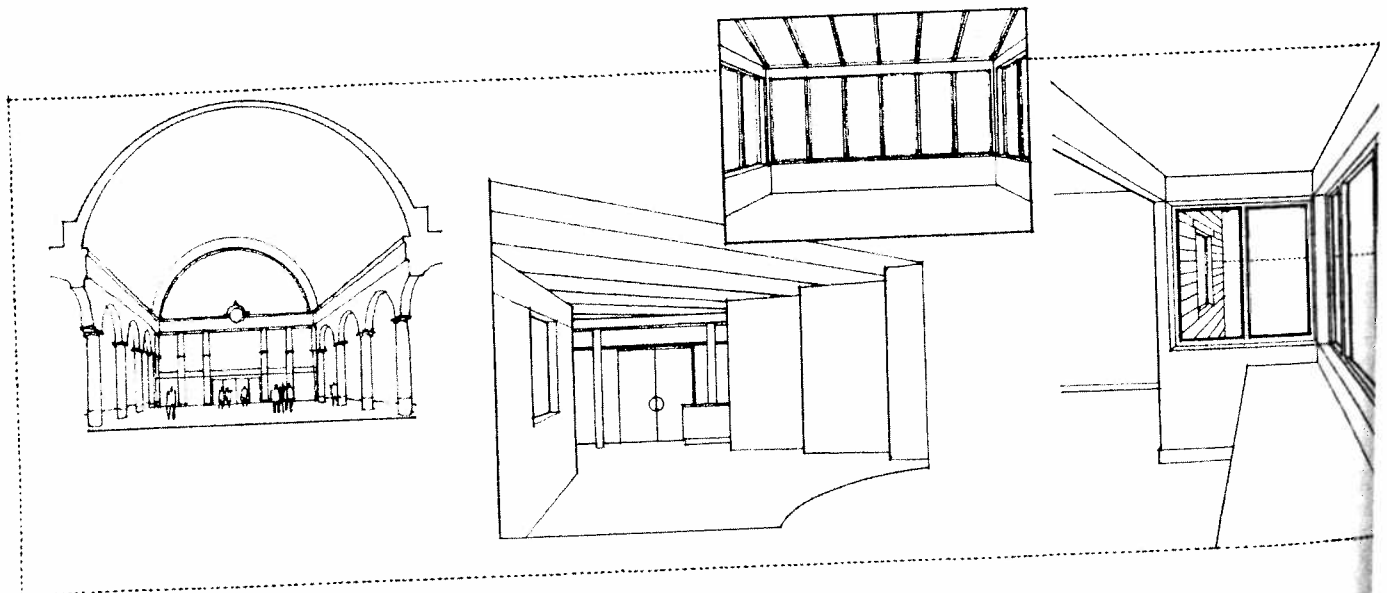

Spatial Qualities

Form • Scale • Light • Outlook

Interior design necessarily goes beyond the architectural definition of space. In planning the layout, furnishing, and enrichment of a space, the interior designer should be acutely aware of its architectural character as well as its potential for modification and enhancement. The design of interior spaces requires, therefore, an understanding of how they are formed by the building systems of structure and enclosure. With this understanding, the interior designer can effectively elect to work with, continue, or even offer a counterpoint to the essential qualities of an architectural space.

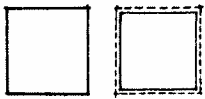
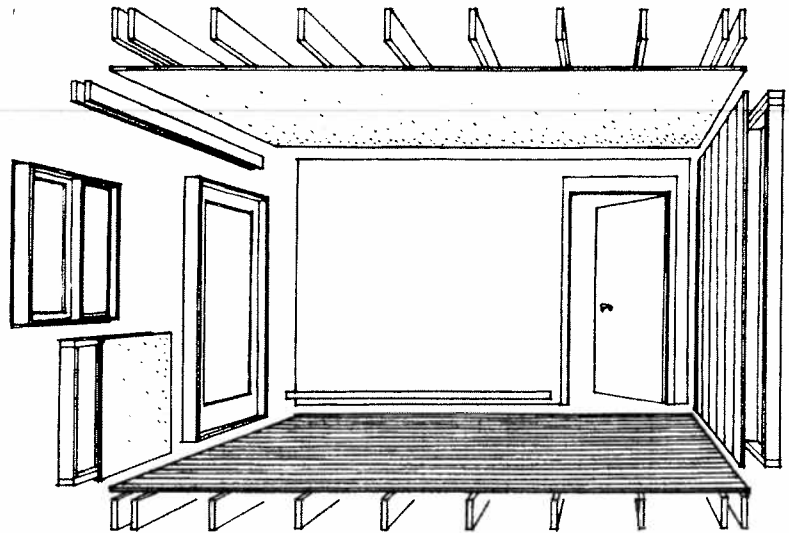

Continuation

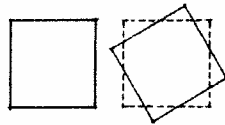

Contrast

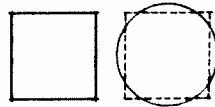

Counterpoint

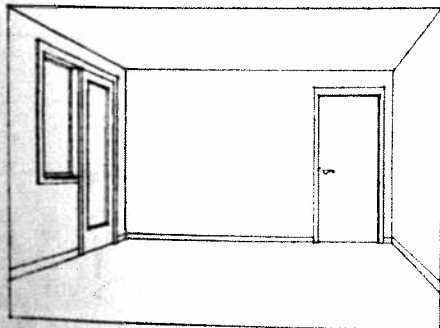

The basic shell

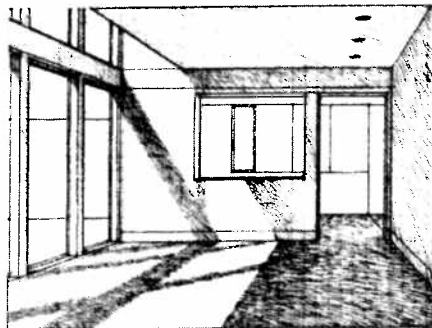

...modified architecturally

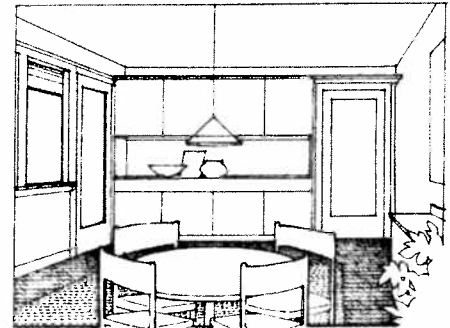

...or through interior design

Interior Space

STRUCTURING SPACE

Buildings typically consist of physical systems of structure, enclosure, and mechanical equipment.

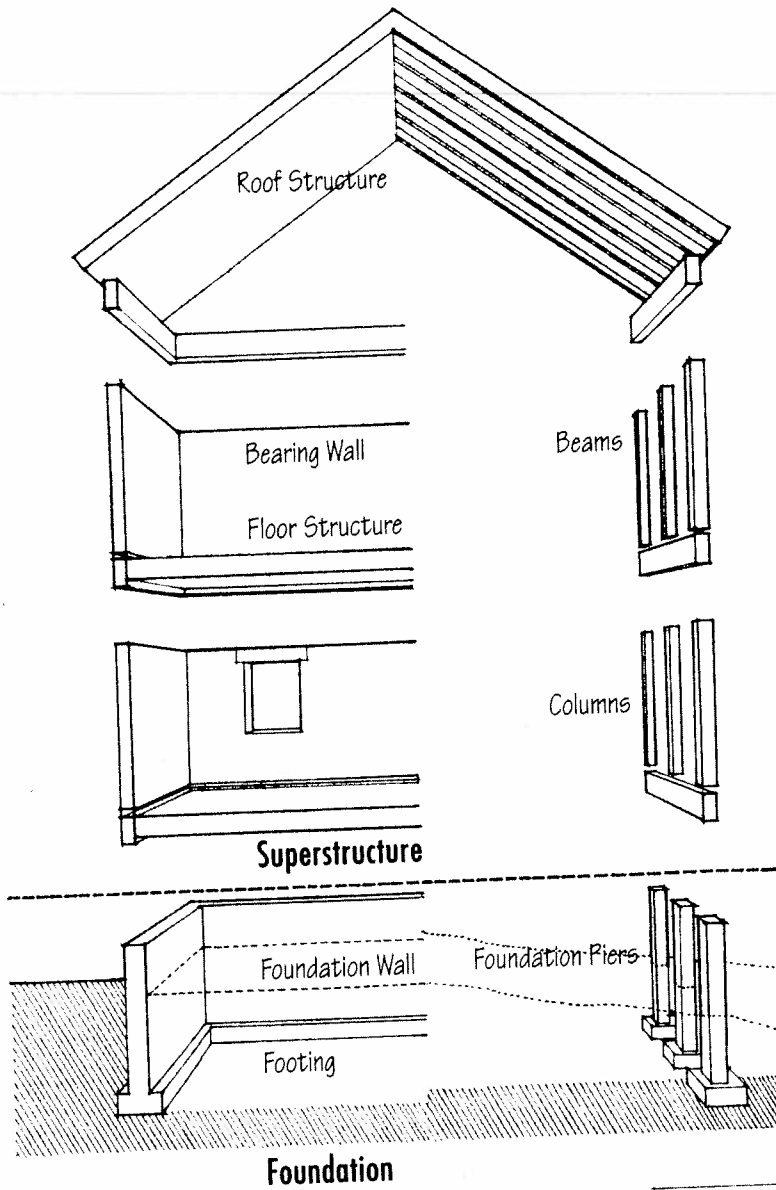

Structural System

- The superstructure is the vertical extension of the foundation system and consists of the columns, beams, and load-bearing walls that support the floor and roof structures.
- The foundation system is the substructure that forms the base of a building, anchors it firmly to the ground, and supports the building elements and spaces above.

These systems must work together to support the following types of loads:

Dead Loads: How a building is constructed determines its dead load, which is a static vertical load comprising the weight of its structural and nonstructural components, including any equipment permanently attached to the structure.

Live Loads: How a building is used determines its live load, which is a movable or moving load comprising the weight of its occupants and any mobile equipment and furnishings. In cold climates, collected snow and water impose an additional live load on a building.

Dynamic Loads: Where a building is located determines its potential loading from the dynamic forces of wind and earthquake.

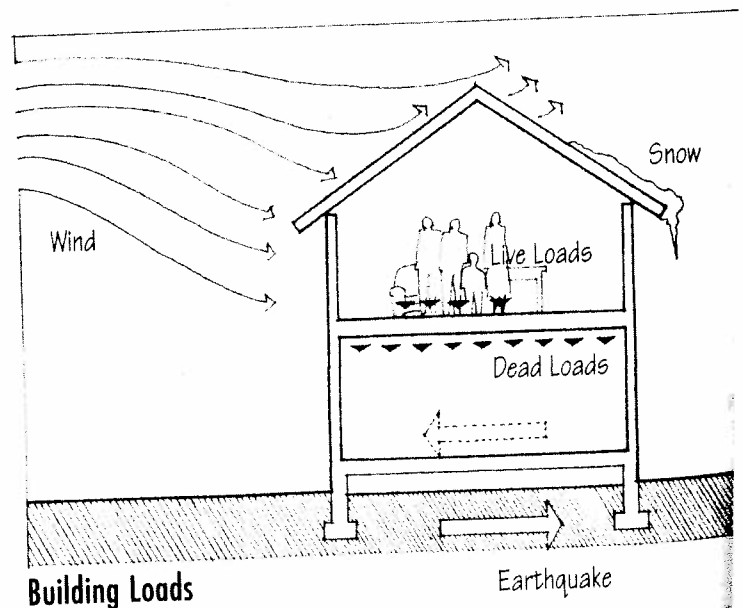

Enclosure System

- The building envelope consists of exterior walls, windows, doors, and roof, which protect and shelter interior spaces from the exterior environment.
- Interior walls, partitions, and ceilings subdivide and define interior space. Many of these components are nonstructural in nature and carry no loads other than their own weight.

Mechanical Systems

- Mechanical systems provide essential services to a building, such as the heating, ventilation, and air-conditioning of interior spaces. Plumbing systems supply water suitable for consumption and firefighting and dispose of sanitary waste. Electrical systems control and safely distribute power for lighting, equipment, security, communication, and vertical transportation.

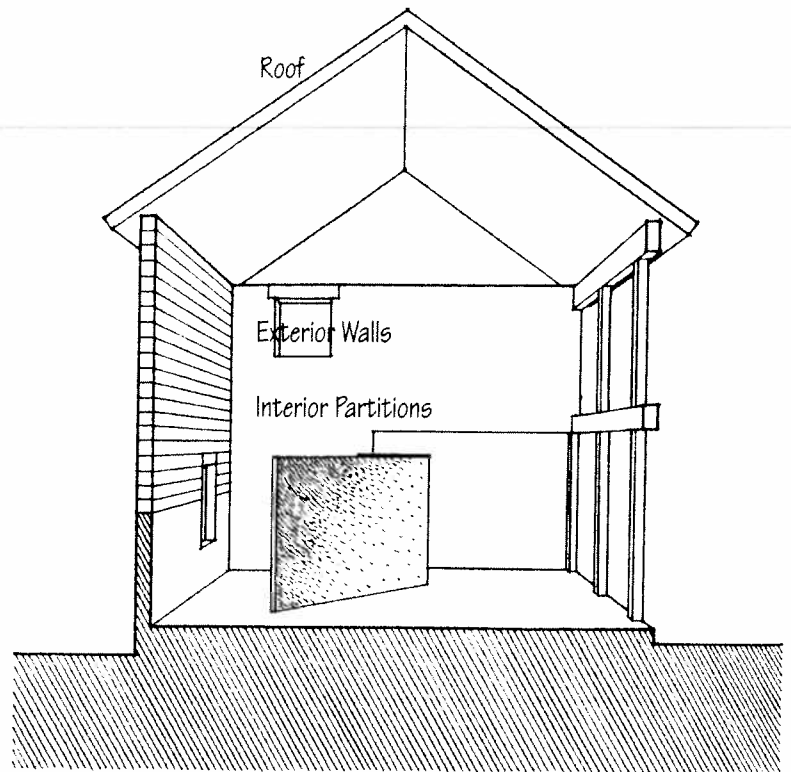

Building Envelope

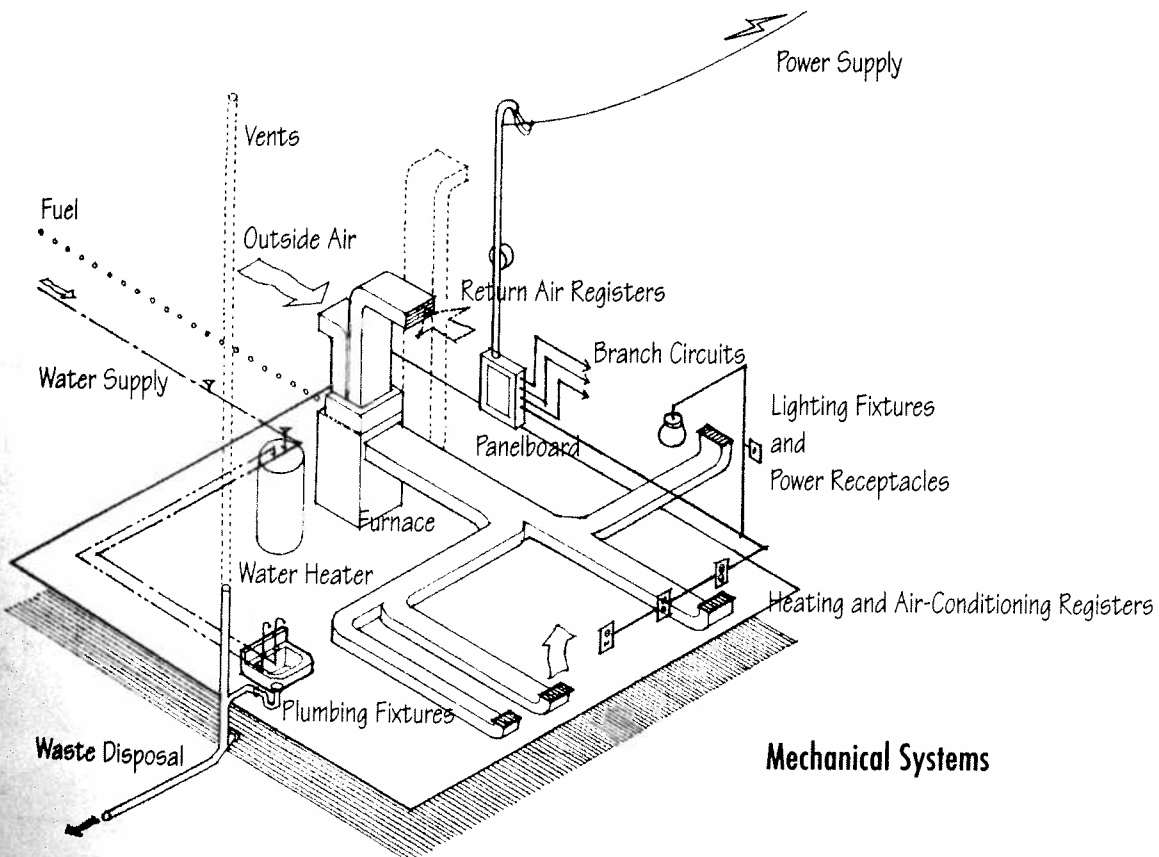

Mechanical Systems

STRUCTURAL SYSTEMS

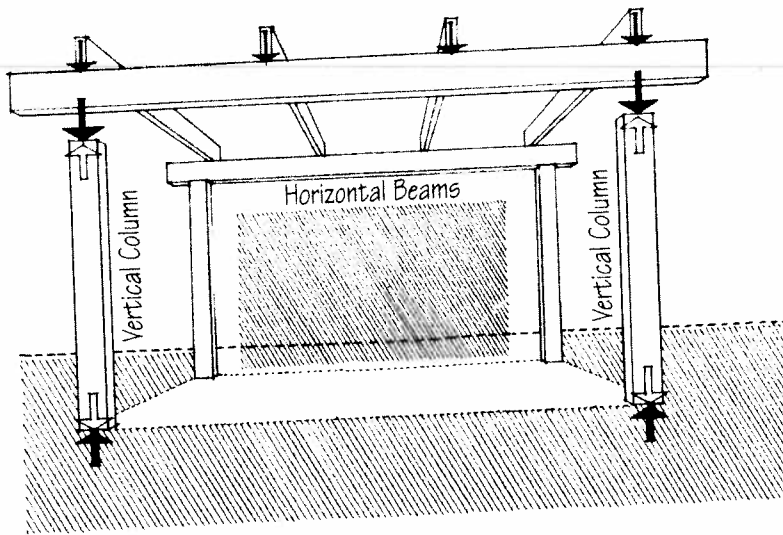

A building's structural system is formed according to the geometry of its materials and how they react to the forces applied to them. This structural form and geometry, in turn, influence the dimensions, proportion, and arrangement of the interior spaces within the building volume.

The two basic linear structural elements are the column and the beam. A column is a vertical support that transmits compressive forces downward along its shaft. The thicker a column is in relation to its height, the greater its load-bearing capacity and its ability to resist buckling resulting from off-center loading or lateral forces.

A beam is a horizontal member that transmits forces perpendicular to itself along its length to its supports. A beam is subject to bending and deflection, which results in an internal combination of compressive and tensile stresses. These stresses are proportionally greater along the upper and lower regions of a beam's cross-section. Increasing depth and placing material where stresses are greatest optimizes a beam's performance.

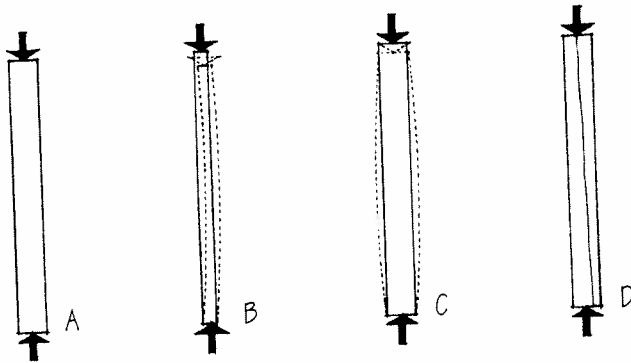

- Columns are subject to compression.
- Slender columns are susceptible to buckling.
- Thick columns may compress, or
- In the case of timber or concrete, they may split or fracture.

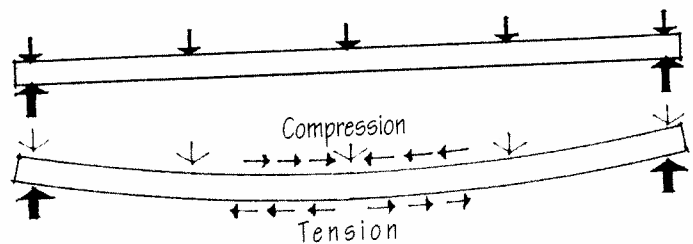

Beams are subject to bending.

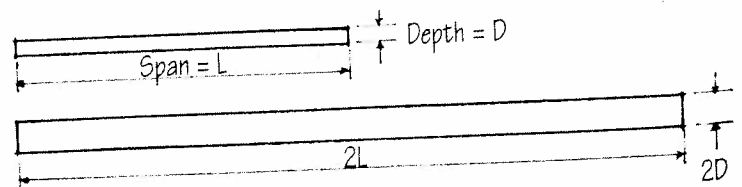

Increasing a beam's depth enables it to span greater distances.

Columns mark points in space and provide a measure for its horizontal divisions. Beams make structural and visual connections across the space between their supports. Together, columns and beams form a skeletal framework around interconnected volumes of space.

While a linear structural system may suggest a grid layout of repetitive spaces, floor, walls, and ceiling planes are necessary for the support and enclosure of interior space. Floor and ceiling planes, which define the vertical limits of space, may consist of planar slabs or a hierarchical arrangement of girders (large, primary beams) and beams and joists (a series of smaller, parallel beams). Walls and partitions need not be load-bearing and do not have to be aligned with the columns of a structural frame except when serving as shear walls and providing for lateral stability. They are free to define the horizontal dimensions of space according to need, desire, or circumstance.

Linear structural systems are cumulative by nature and eminently flexible. They allow for growth, change, and the adaptation of individual spaces to their specific uses.

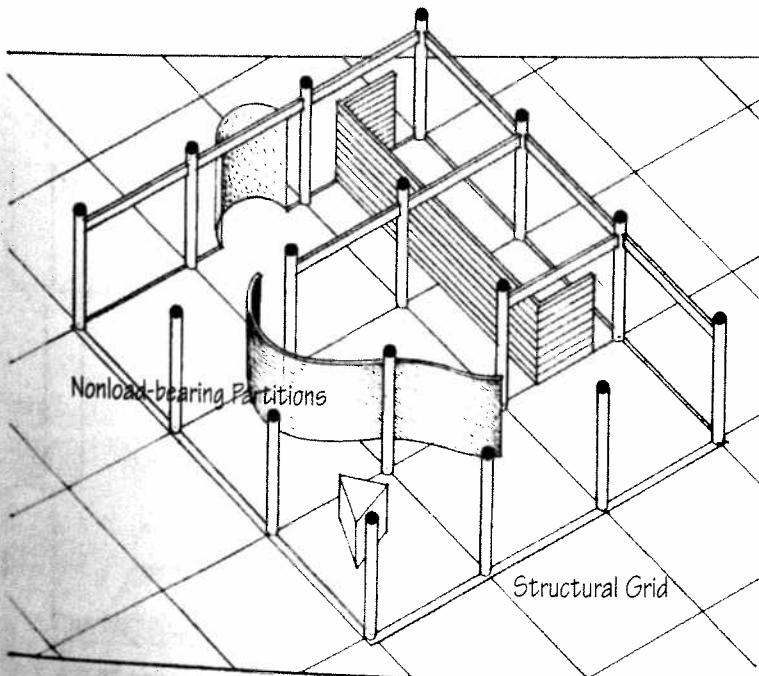
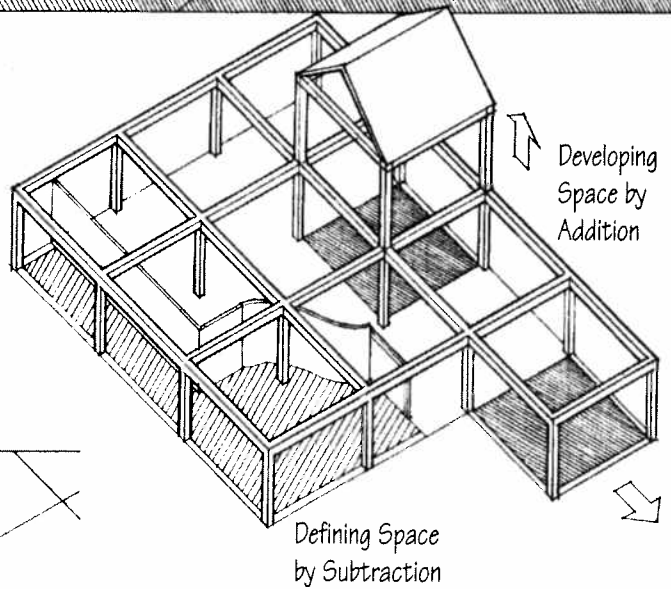
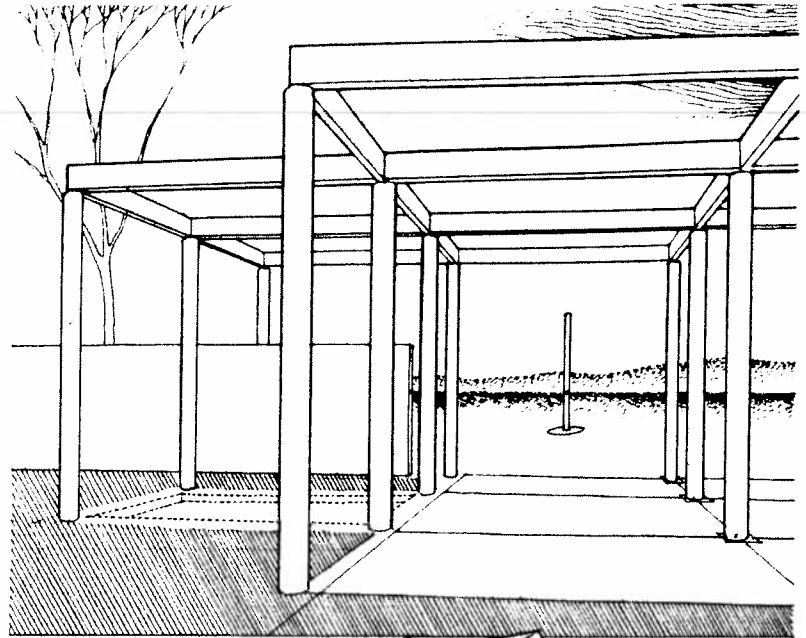

PLANAR STRUCTURAL SYSTEMS

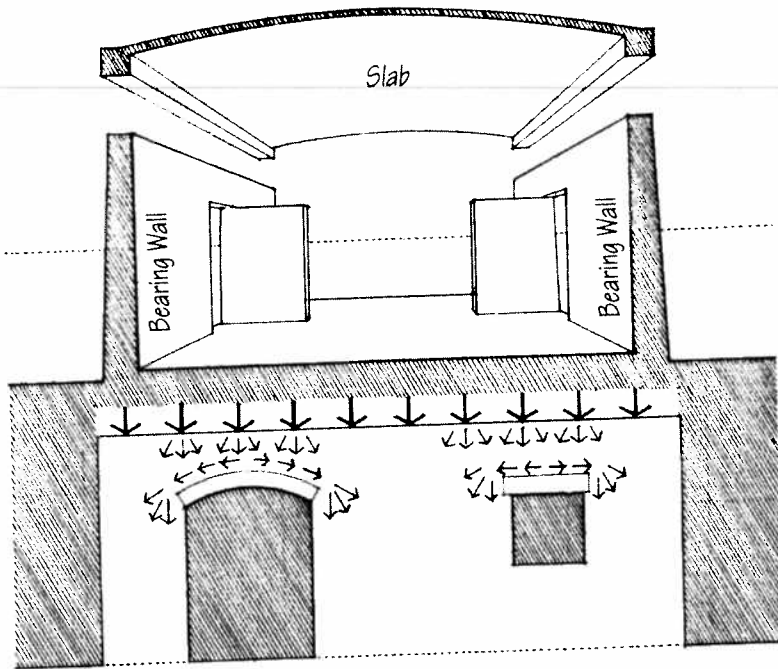

Small beams or lintels are required to span openings in bearing walls.

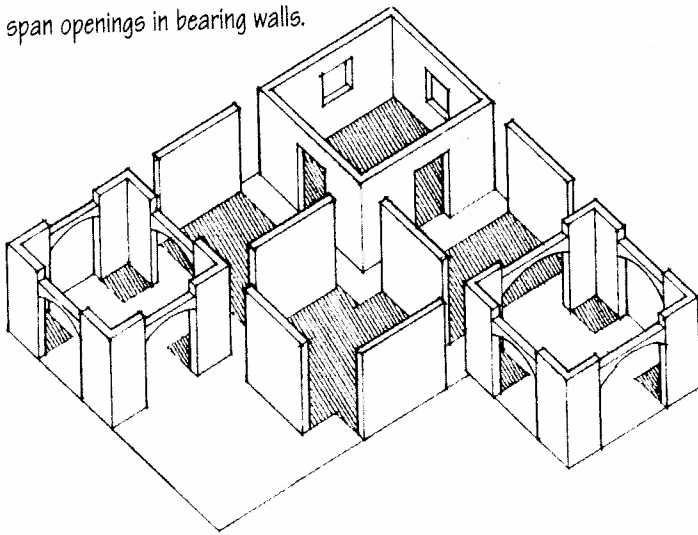

Varying degrees of spatial enclosure are possible with walls, depending on the size and location of openings within their planes.

The two principal types of planar structural elements are the load-bearing wall and the horizontal slab. A bearing wall acts as a long, thin column in transmitting compressive forces to its support or foundation.

Window and door openings within a bearing wall tend to weaken its structural integrity. Any opening must be spanned by an arch or a short beam called a lintel to support the wall load above and allow compressive stresses to flow around the opening to adjacent sections of the wall.

A common pattern for bearing walls is a parallel layout spanned by floor joists and roof rafters or by horizontal slabs. For lateral stability, pilasters and cross walls are often used to help brace bearing walls.

While linear structural elements outline the edges of spatial volumes, planar elements such as the bearing wall define the physical limits of space. They provide a real sense of enclosure and serve as barriers against the elements.

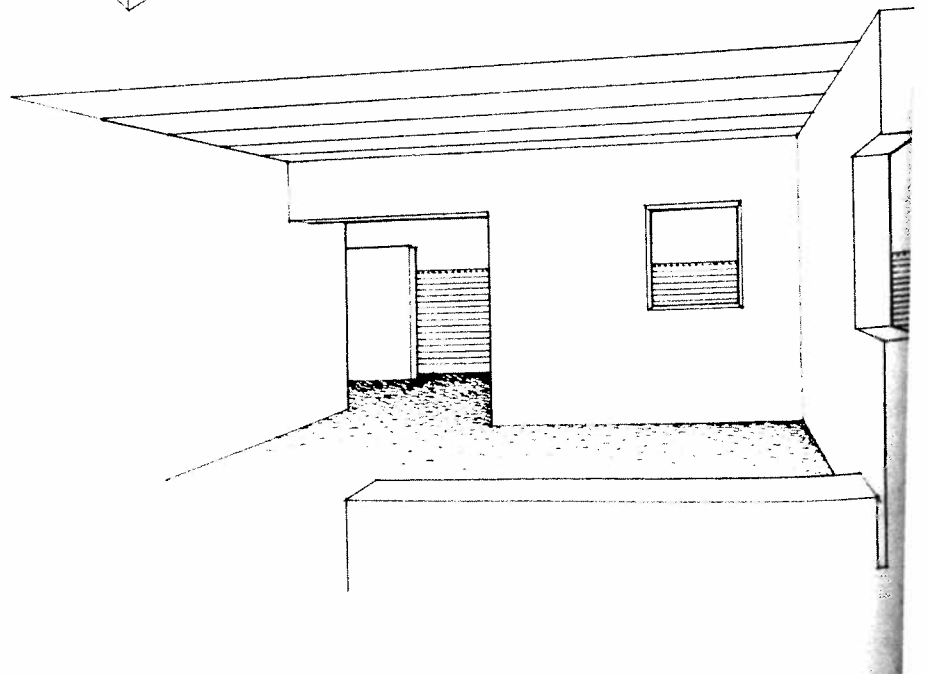

PLANAR STRUCTURAL SYSTEMS

A slab is a horizontal, rigid, usually monolithic plate. A common example is a reinforced concrete slab. A slab is able to support both concentrated and distributed loads because the resulting stresses can fan out across the plane of the slab and take various paths to the slab supports.

When supported along two edges, a slab can be considered a wide, shallow beam extending in one direction. Supported along four sides, a slab becomes a two-way structural element. For greater efficiency and reduced weight, a slab can be modified in section to incorporate ribs.

When integrally connected with reinforced concrete columns, flat slabs can be supported without beams. They form horizontal layers of space punctuated only by the shafts of the supporting columns.

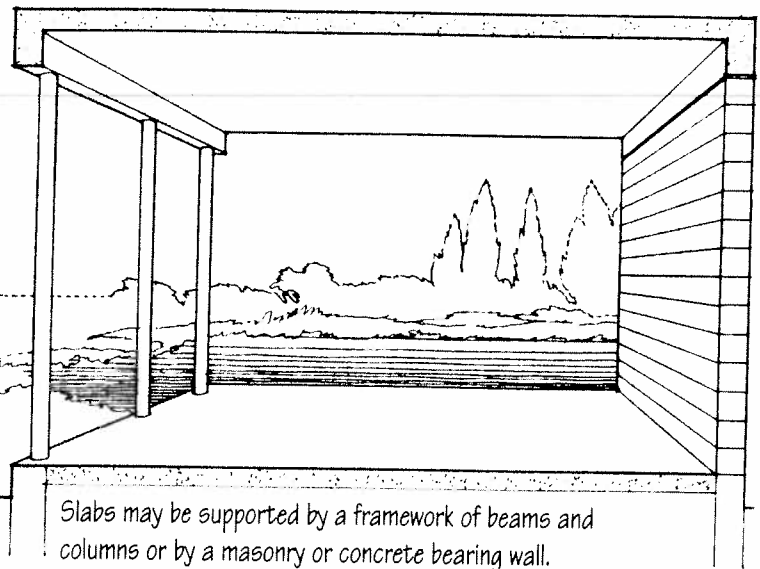

Slabs may be supported by a framework of beams and columns or by a masonry or concrete bearing wall.

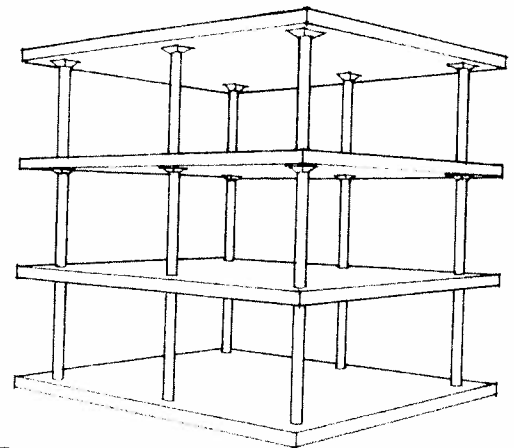

Two-way flat slabs thickened at their column supports define horizontal layers of space.

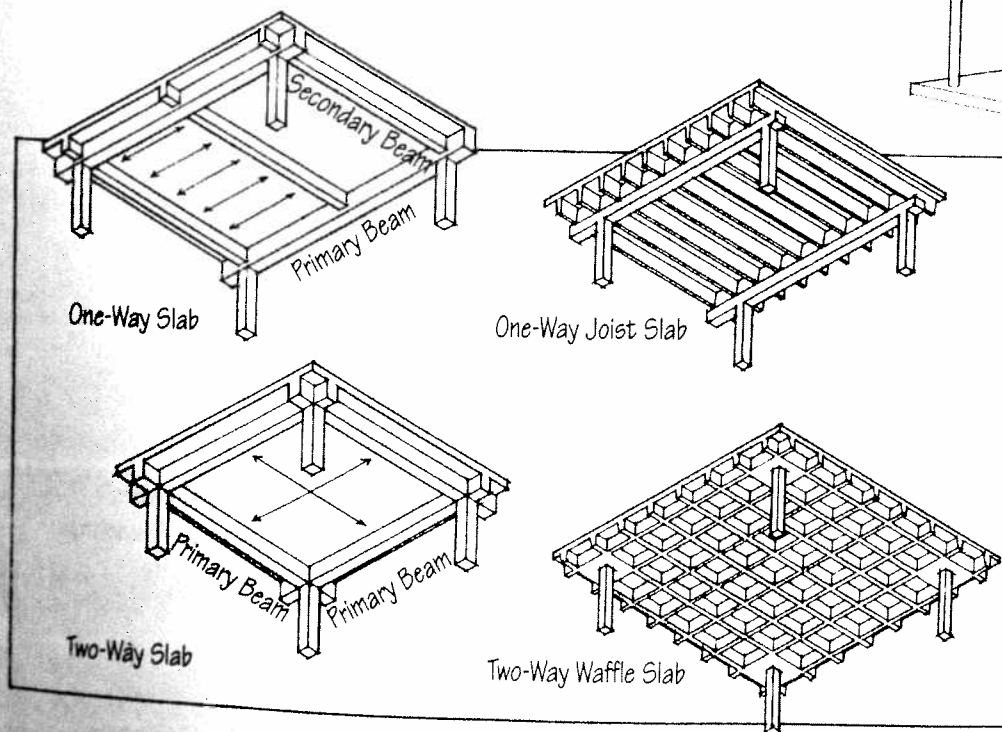

VOLUMETRIC STRUCTURAL SYSTEMS

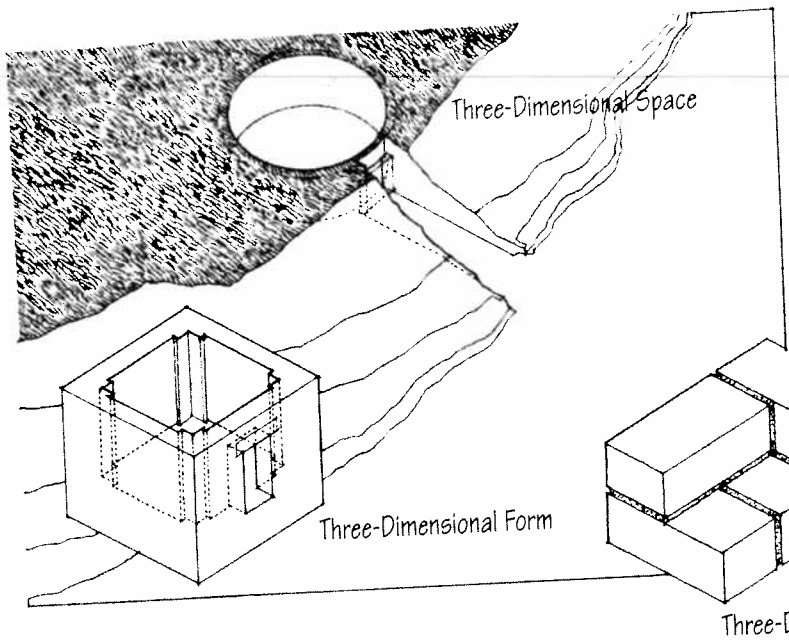

A volumetric structural system consists of a three-dimensional mass. The mass of the material occupies the void of space. Out of the mass is carved the volume of interior space. Because of the efficiency of engineering methods and the strength of modern building materials, pure volumetric structural systems are quite rare today. At a small scale, however, stone and clay masonry units can be seen to be volumetric structural elements. At a larger scale, any building that encloses interior space can be viewed as a three-dimensional structure that must have strength in width, length, and depth.

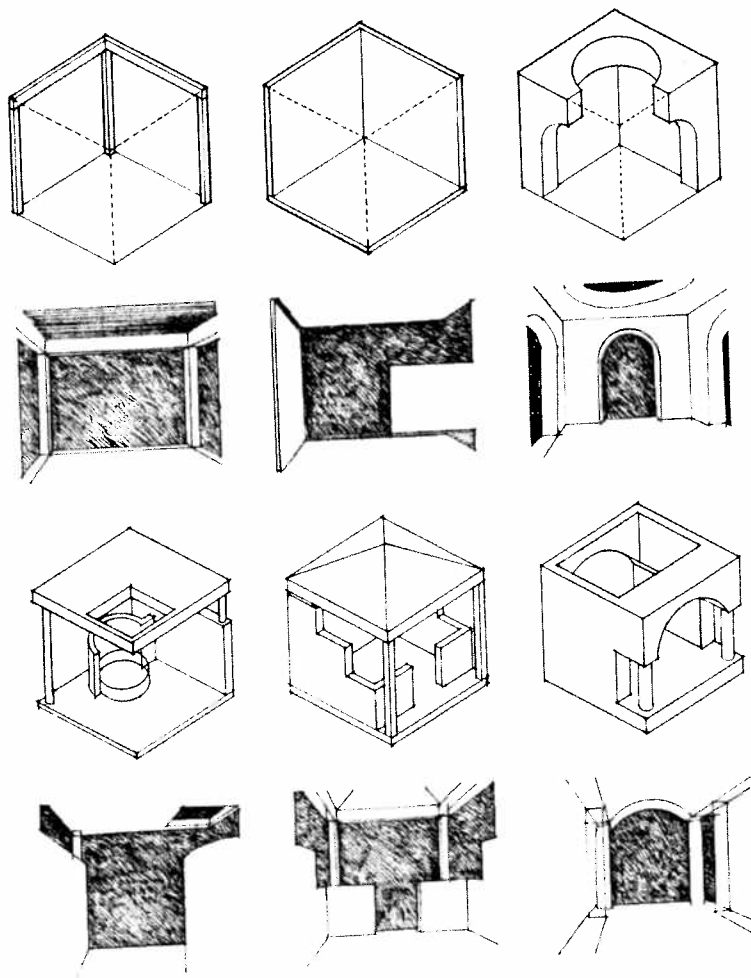

Composite systems combine linear, planar, and volumetric elements into three-dimensional compositions of form and space.

COMPOSITE STRUCTURAL SYSTEMS

Most structural systems are in fact composites of linear, planar, and volumetric elements. No one system is superior to all others in all situations. For the structural designer, each presents advantages and disadvantages, depending on the size, location, and intended use of a building. An interior designer should be aware of the character of the interior spaces each system defines.

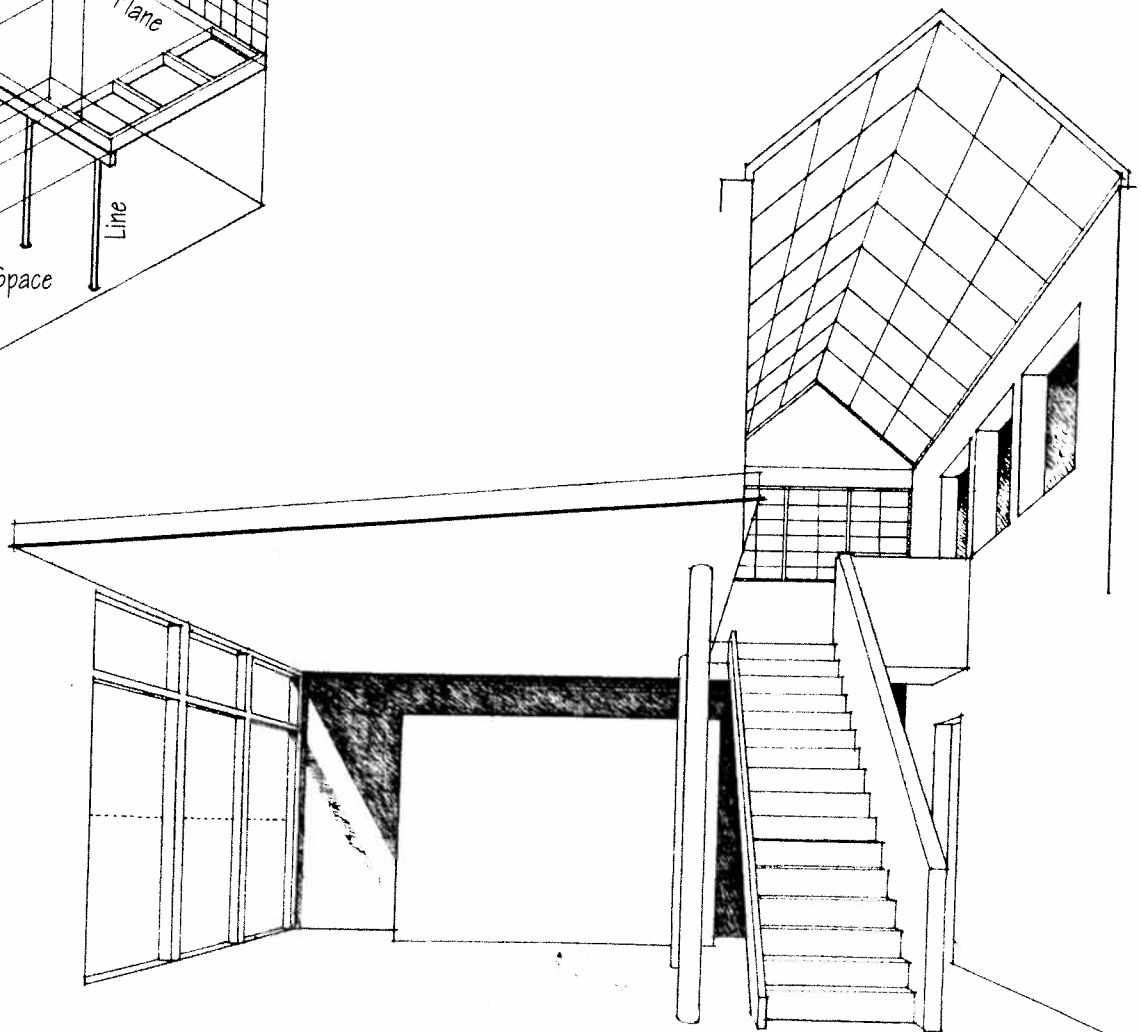
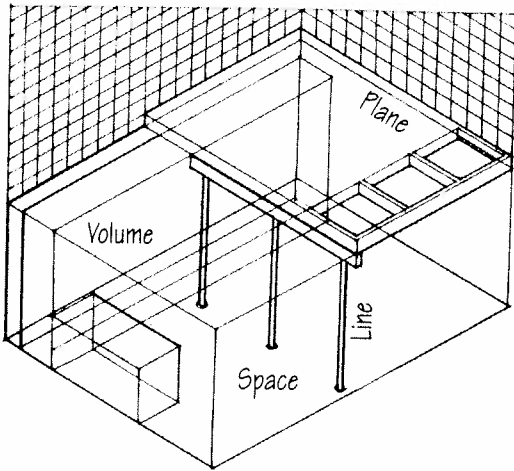
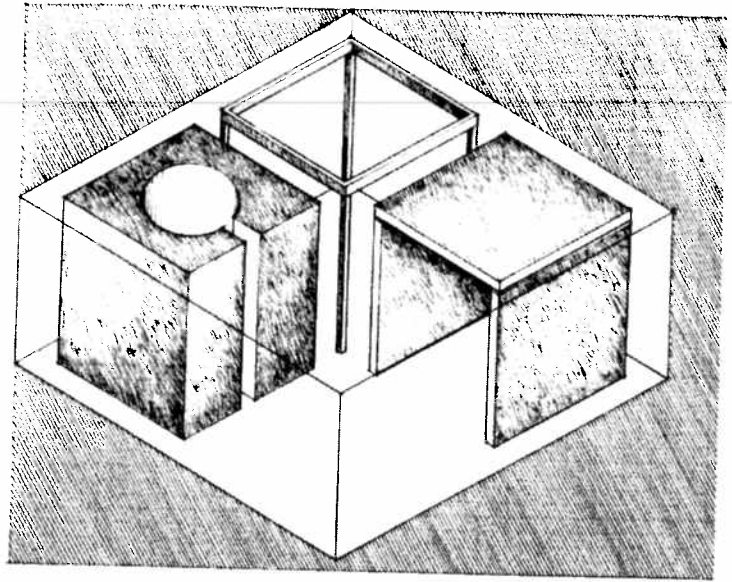

SHAPING INTERIOR SPACE

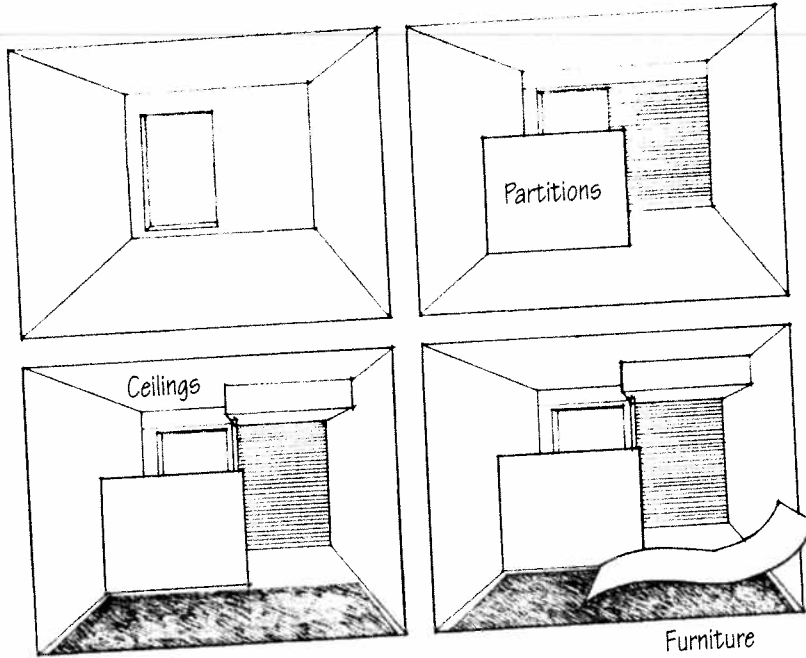

While a building's structural system sets up the basic form and pattern of its interior spaces, these spaces are ultimately structured by the elements of interior design. The term structure is not used here in the sense of physical support. It refers to the selection and arrangement of interior elements such that their visual relationships define and organize the interior space of a room.

- Nonload-bearing partitions and suspended ceilings are often used to define or modify space within the structural framework or shell of a building.
- The color, texture, and pattern of wall, floor, and ceiling surfaces affect our perception of their relative positions in space and our awareness of the room's dimensions, scale, and proportion.

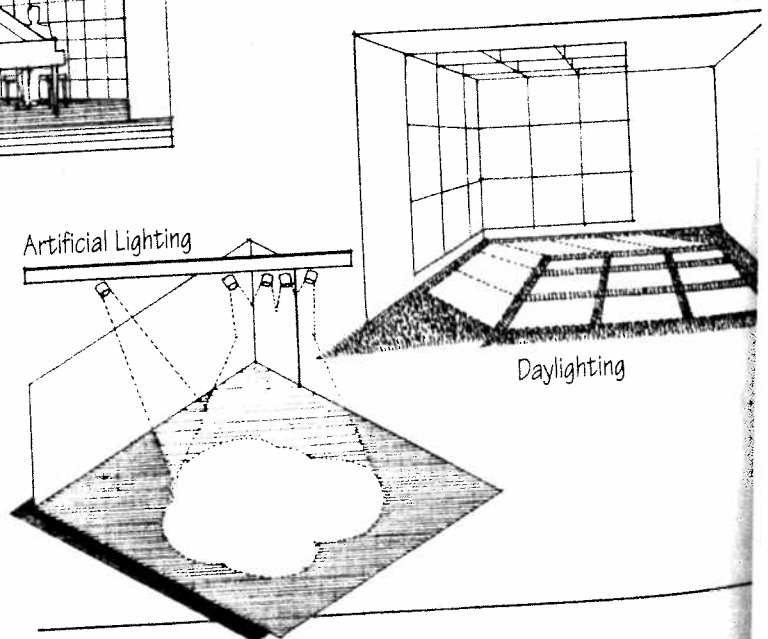
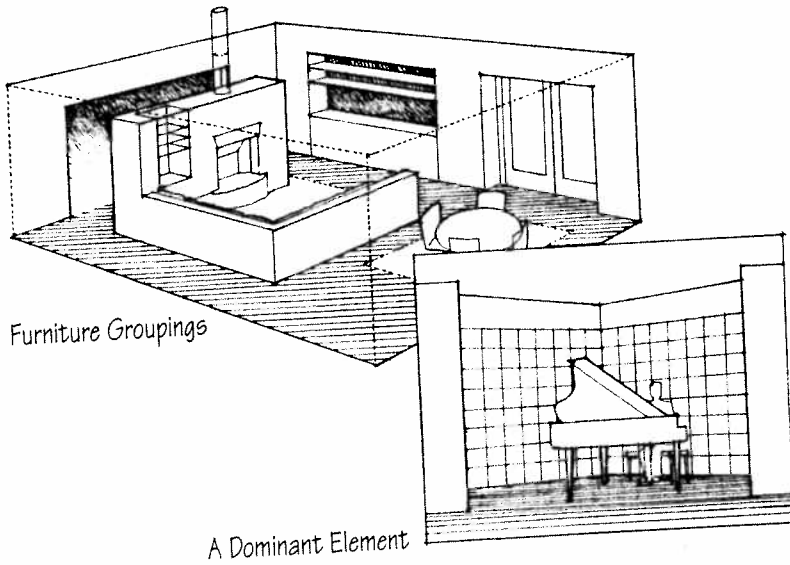

Structuring Space with Interior Design Elements

SHAPING INTERIOR SPACE

- Within a large space, the form and arrangement of furnishings can divide areas, provide a sense of enclosure, and define spatial patterns.
- Lighting, and the light-and-dark patterns it creates, can call our attention to one area of a room, de-emphasize others, and thereby create divisions of space.
- Even the acoustic nature of a room's surfaces can affect the apparent boundaries of a space. Soft, absorbent surfaces muffle sounds and can diminish our awareness of the physical dimensions of a room. Hard surfaces that reflect sounds within a room help to define its physical boundaries. Echoes can suggest a large volume.
- Finally, space is structured by how we use it. The nature of our activities and the rituals we develop in performing them influence how we plan, arrange, and organize interior space.

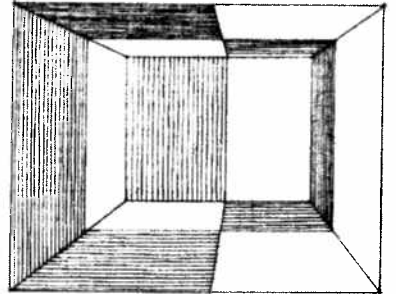
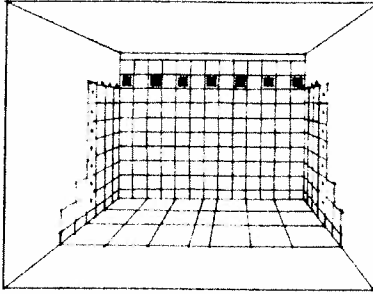
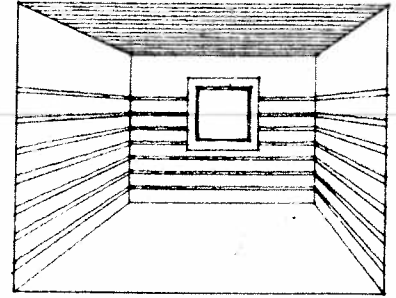
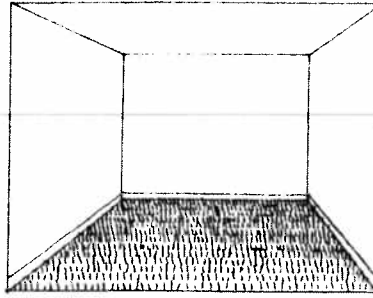

Color, Texture, and Pattern

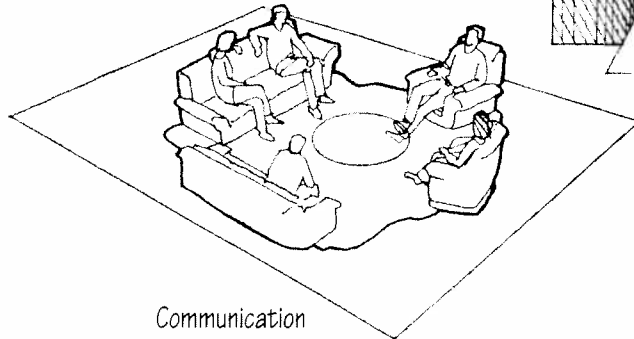
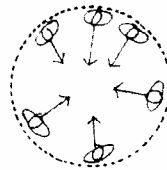

Communication

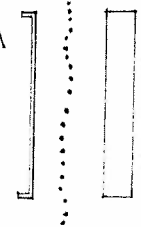
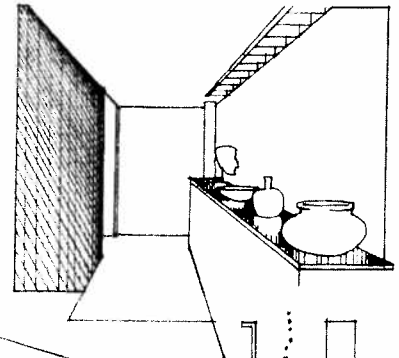

Movement

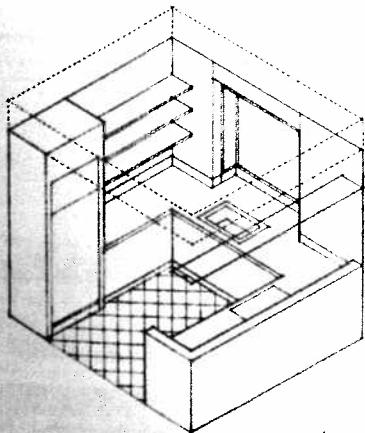

Individual and Group Activities

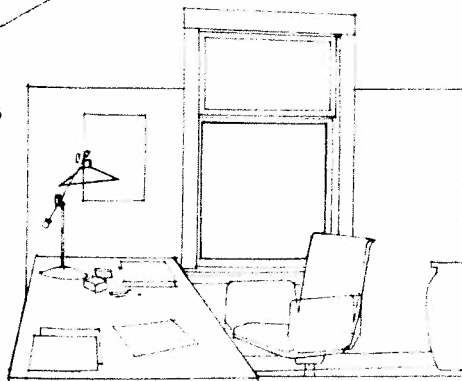

SPATIAL FORM

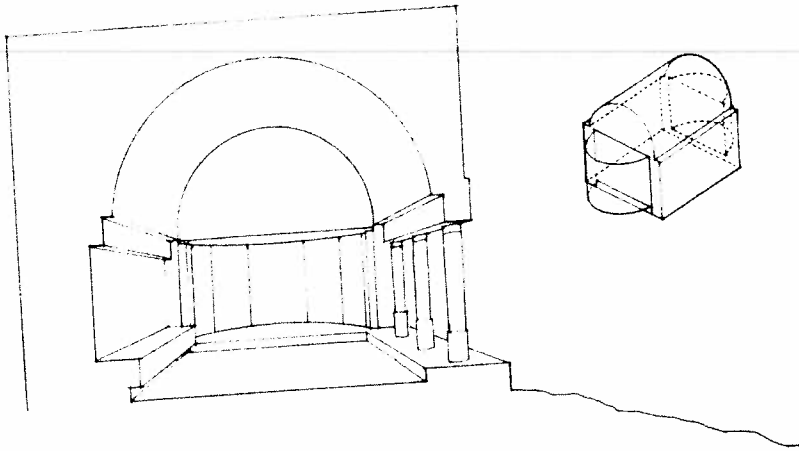

Interior spaces are formed first by a building's structural system, further defined by wall and ceiling planes, and related to other spaces by windows and doorways. Every building has a recognizable pattern of these elements and systems. Each pattern has an inherent geometry that molds or carves out a volume of space into its likeness.

It is useful to be able to read this figure-ground relationship between the form of space-defining elements and that of the space defined. Either the structure or the space can dominate this relationship. Even as one appears to dominate, we should be able to perceive the other as an equal partner in the relationship.

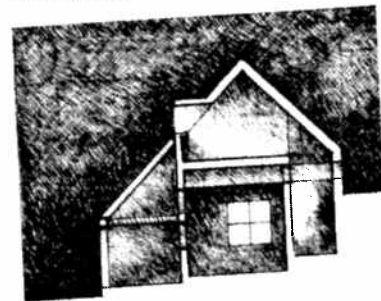
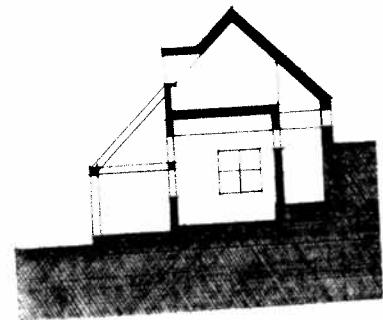
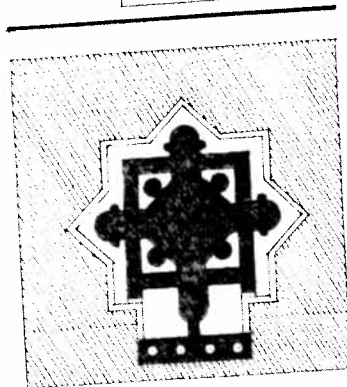
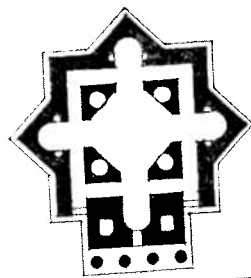
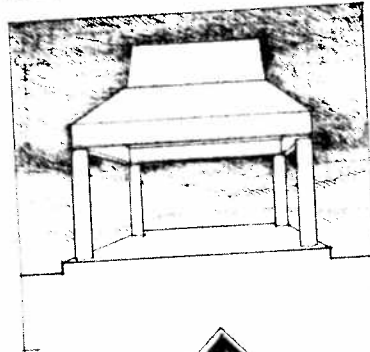
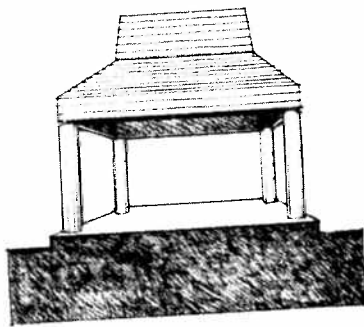

It is equally useful to see this alternating figure-ground relationship occurring as interior design elements, such as tables and chairs, are introduced and arranged within an interior space.

When a chair is placed in a room, it not only occupies space, it also creates a spatial relationship between itself and the surrounding enclosure. We should see more than the form of the chair. We should also recognize the form of the space surrounding the chair after it has filled some of the void.

As more elements are introduced into the pattern, the spatial relationships multiply. The elements begin to organize into sets or groups, each of which not only occupies space but also defines and articulates the spatial form.

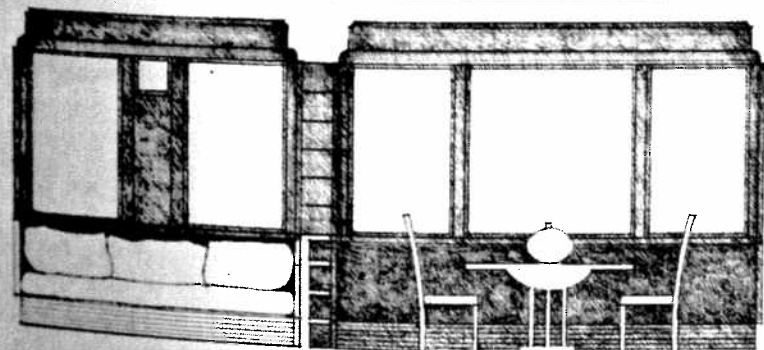
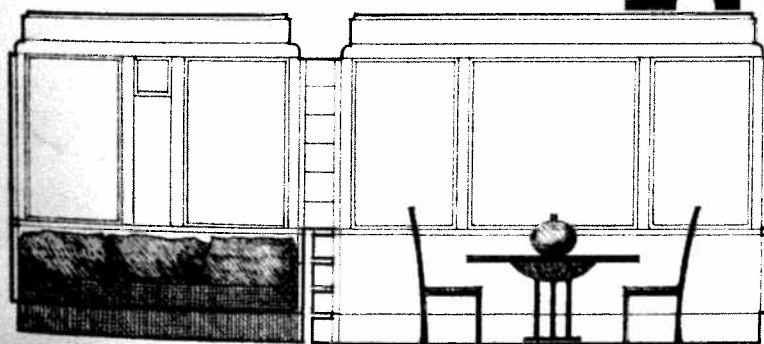
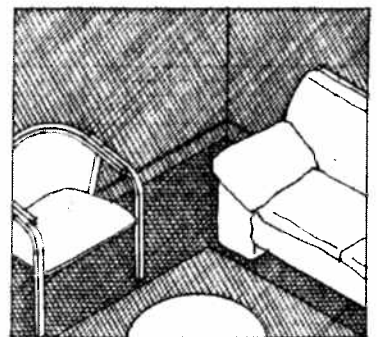
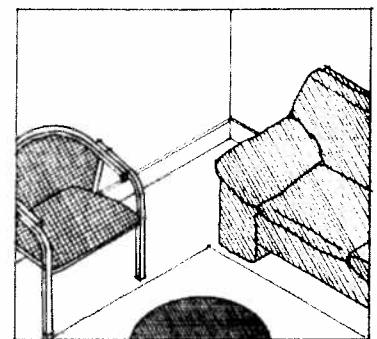
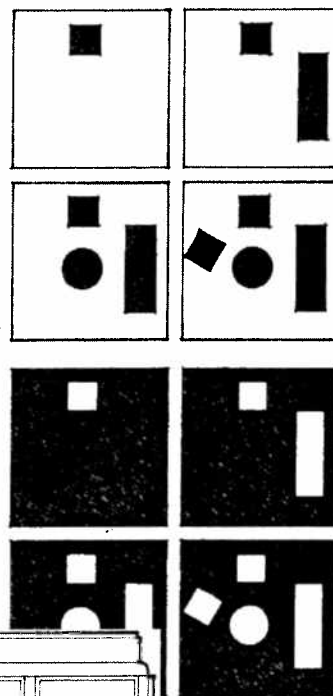
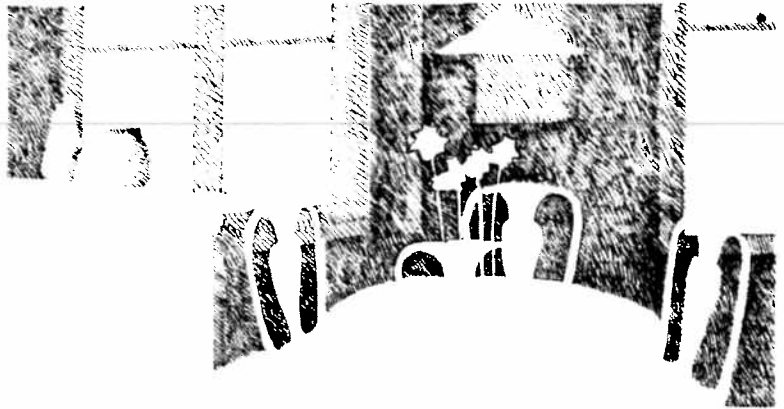

SPATIAL DIMENSIONS

The dimensions of interior space, like spatial form, are directly related to the nature of a building's structural system—the strength of its materials and the size and spacing of its members. The dimensions of space, in turn, determine a room's proportion and scale and influence how it is used.

One horizontal dimension of space, its width, has traditionally been limited by the materials and techniques used to span it. Today, given the necessary economic resources, almost any architectural structure is technically possible. Wood or steel beams and concrete slabs can span up to 30 feet (9 m). Wood or steel trusses can span even farther, up to 100 feet (30 m) or more. Longer roof spans are possible with space frames and a variety of curved structures, such as domes, suspension systems, and membranes supported by air pressure.

While the width of an interior space may be limited by structural necessity, it should be established by the requirements of those who use the space and their need to set boundaries for themselves and their activities.

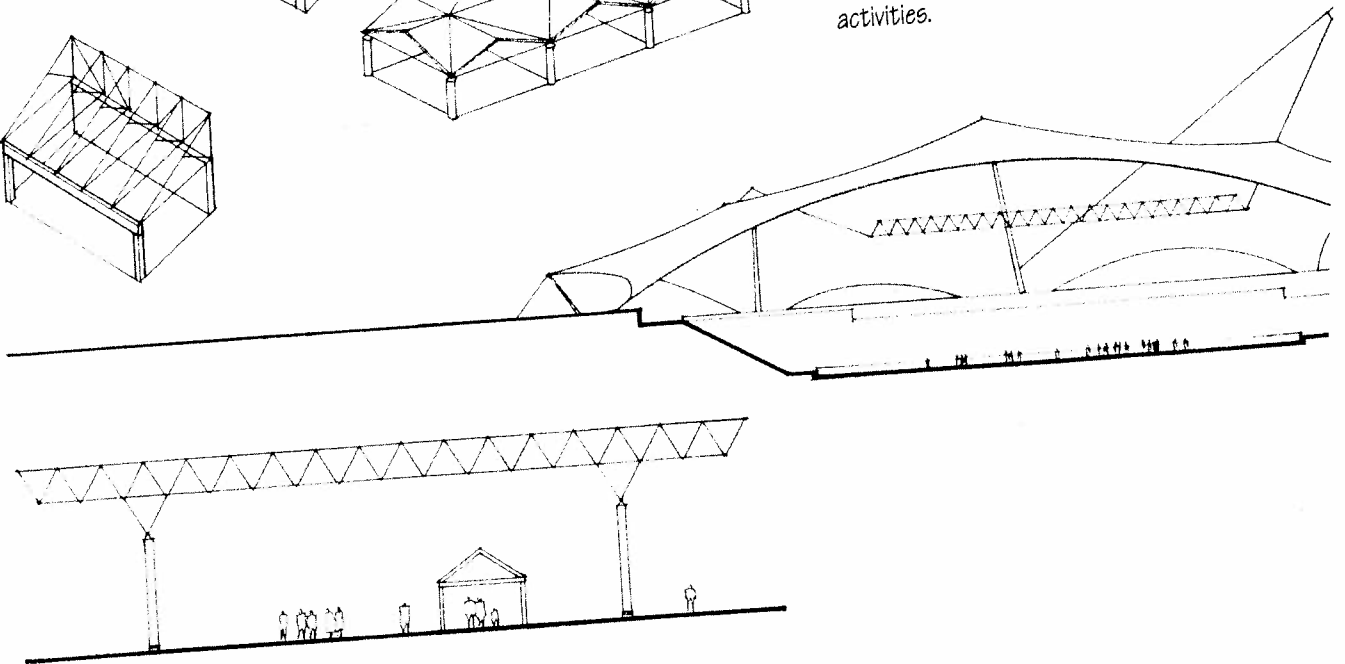
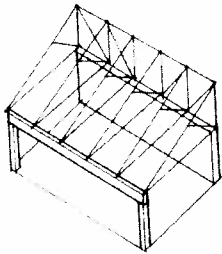
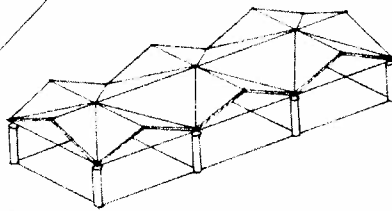
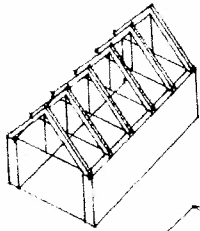
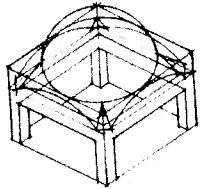
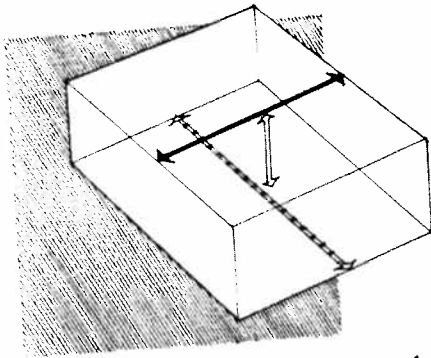

The other horizontal dimension of space, its length, is limited by desire and circumstance. Together with width, the length of a space determines the proportion of a room's plan shape.

A square room, where the length of the space equals its width, is static in quality and often formal in character. The equality of the four sides focuses on the room's center. This centrality can be enhanced or emphasized by covering the space with a pyramidal or dome structure.

To de-emphasize the centrality of a square room, the form of the ceiling can be made asymmetrical or one or more of the wall planes can be treated differently from the others.

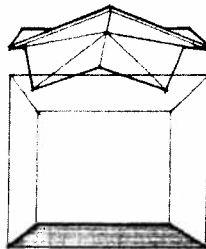
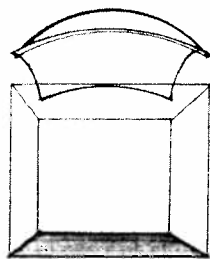
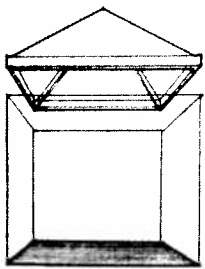
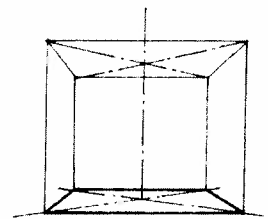
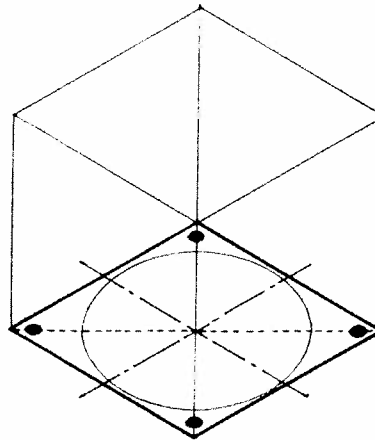
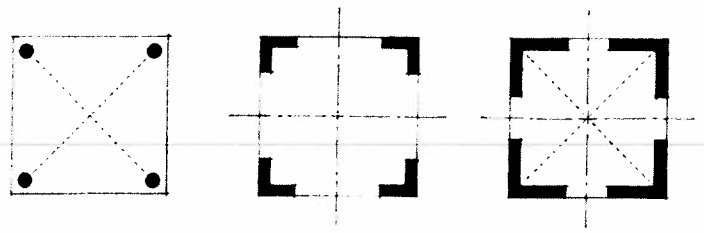

Pyramids, domes, and similar roof forms can emphasize the centrality of square spaces.

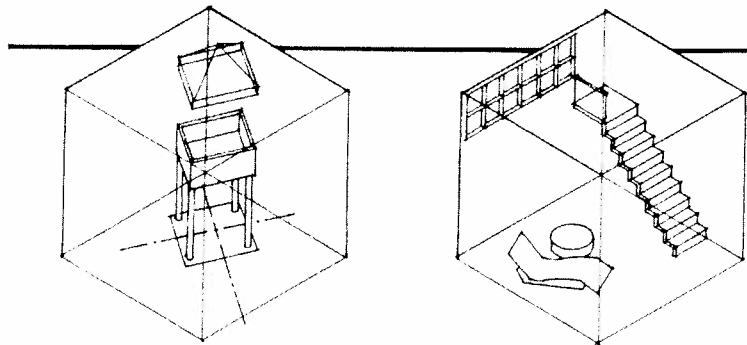
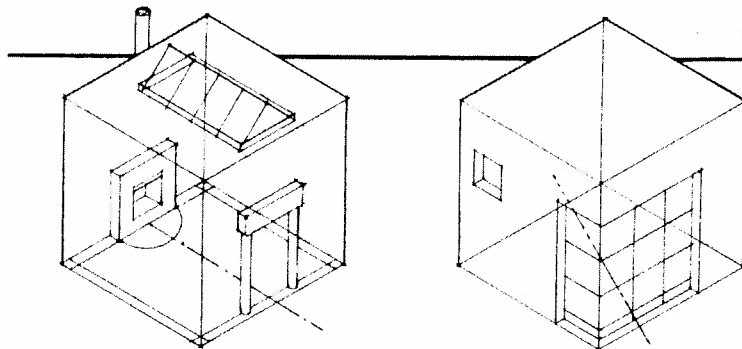

The placement of architectural elements, such as windows and stairways, can de-emphasize the centrality of square spaces.

RECTANGULAR SPACES

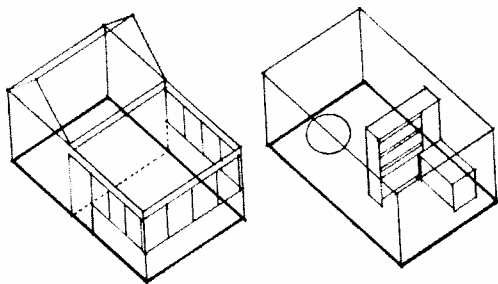
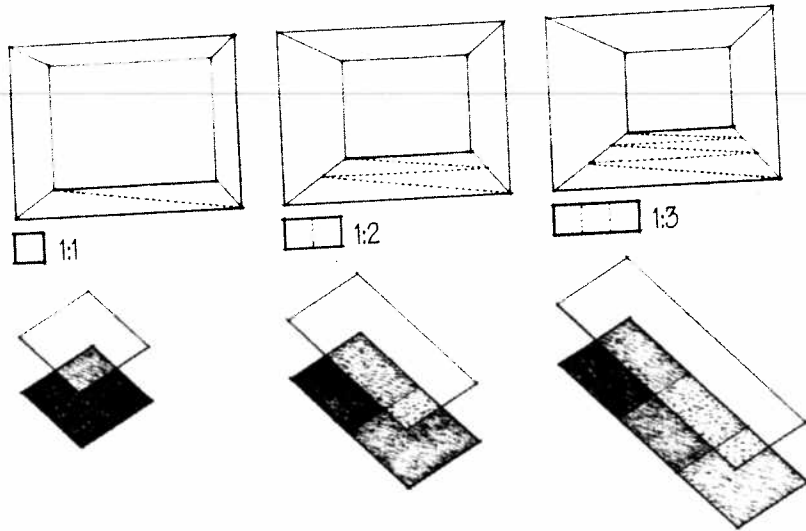

Horizontal dimensions alone do not determine the ultimate qualities and usefulness of a space. They only suggest opportunities for development.

Square rooms are rare and distinctive. More often, a room will have a length greater than its width. A rectangular space, normally spanned across its width, is eminently flexible. Its character and usefulness are determined not only by its proportion of width to length but also by the configuration of its ceiling, the pattern of its windows and doorways, and its relationship to adjacent spaces.

When the length of a space is greater than twice its width, it tends to dominate and control the room's layout and use. Given sufficient width, the space can be divided into a number of separate but related areas.

A space whose length greatly exceeds its width encourages movement along its long dimension. This characteristic of linear spaces makes them suitable for use as gallery spaces or as connectors of other spaces.

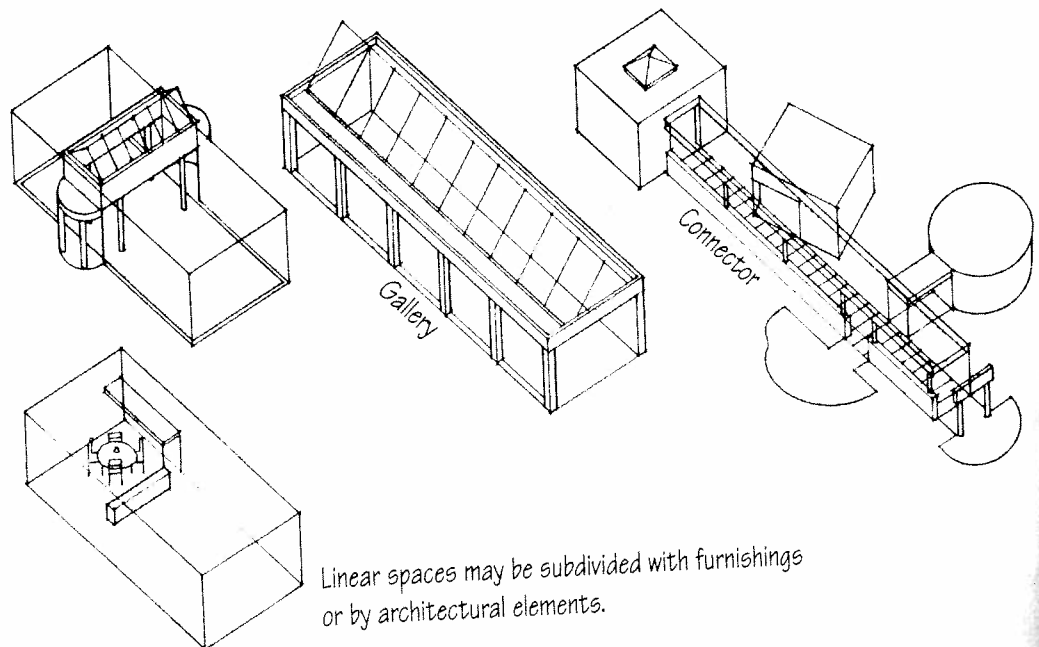

Linear spaces may be subdivided with furnishings or by architectural elements.

Both square and rectangular spaces can be altered by addition or subtraction or by merging with adjacent spaces. These modifications can be used to create an alcove space or to reflect an adjoining circumstance or site feature.

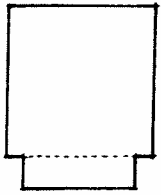

Extension

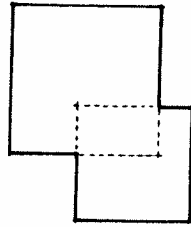

Addition

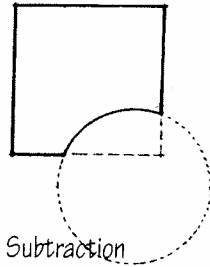

Subtraction

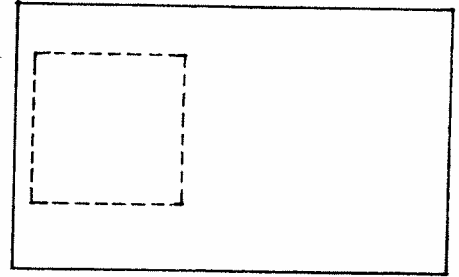

Merging

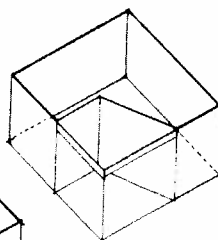
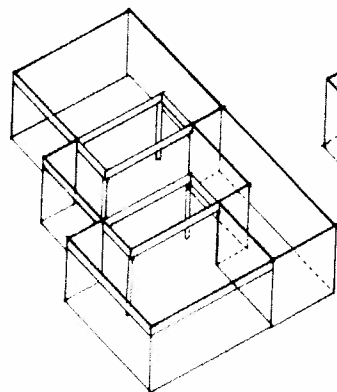
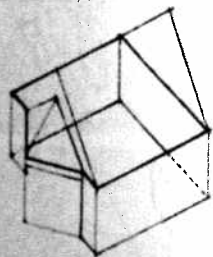
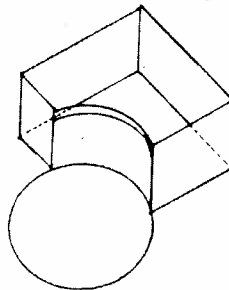
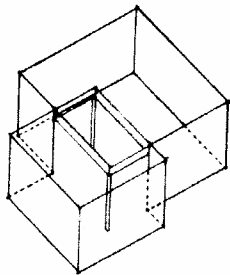
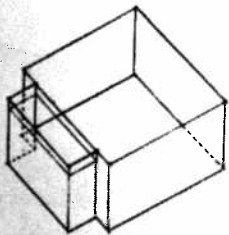
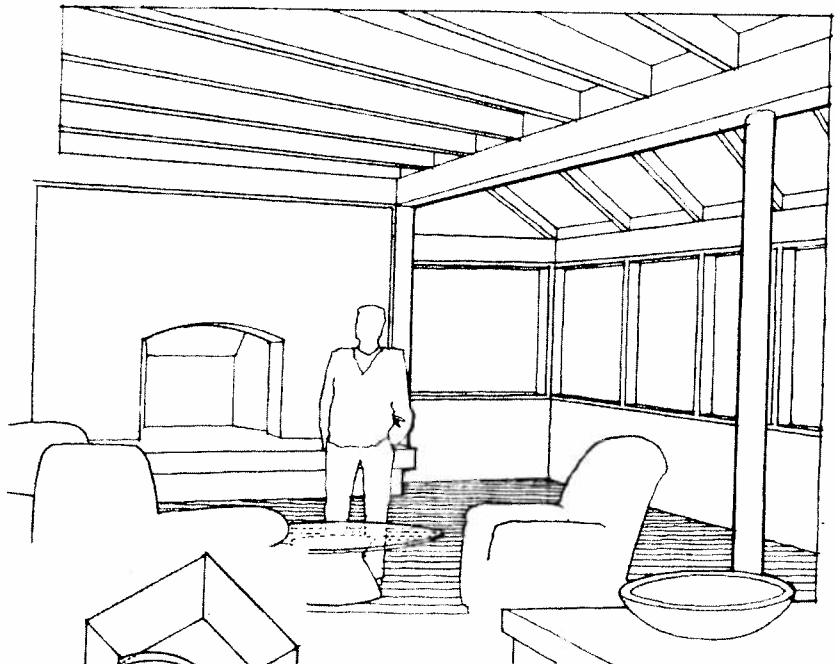

CURVILINEAR SPACES

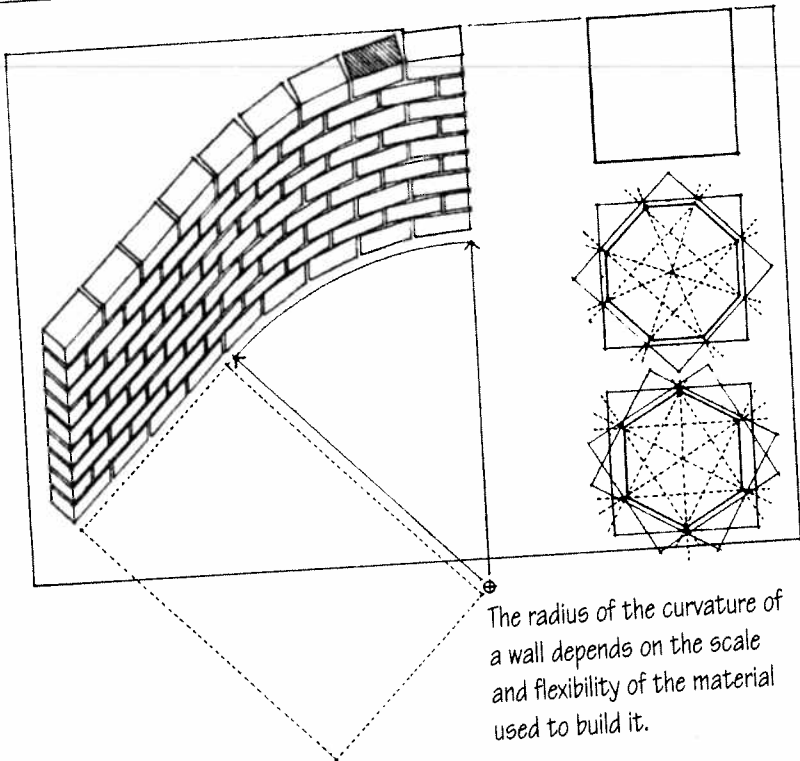

The radius of the curvature of a wall depends on the scale and flexibility of the material used to build it.

The nature of building materials and the techniques used to assemble them establish rectangular spaces as the norm. Curvilinear spaces are exceptional and usually reserved for special circumstances.

The simplest curvilinear space is a circular one. It is compact and self-centering. While focusing in on its center, a circular space also relates to the surrounding space equally in all directions. It has no front, back, or sides, unless defined by other elements.

An elliptical space is more dynamic, having two centers and unequal axes.

Other curvilinear spaces can be seen as transformations of circular or elliptical spaces that have been combined in an overlapping manner.

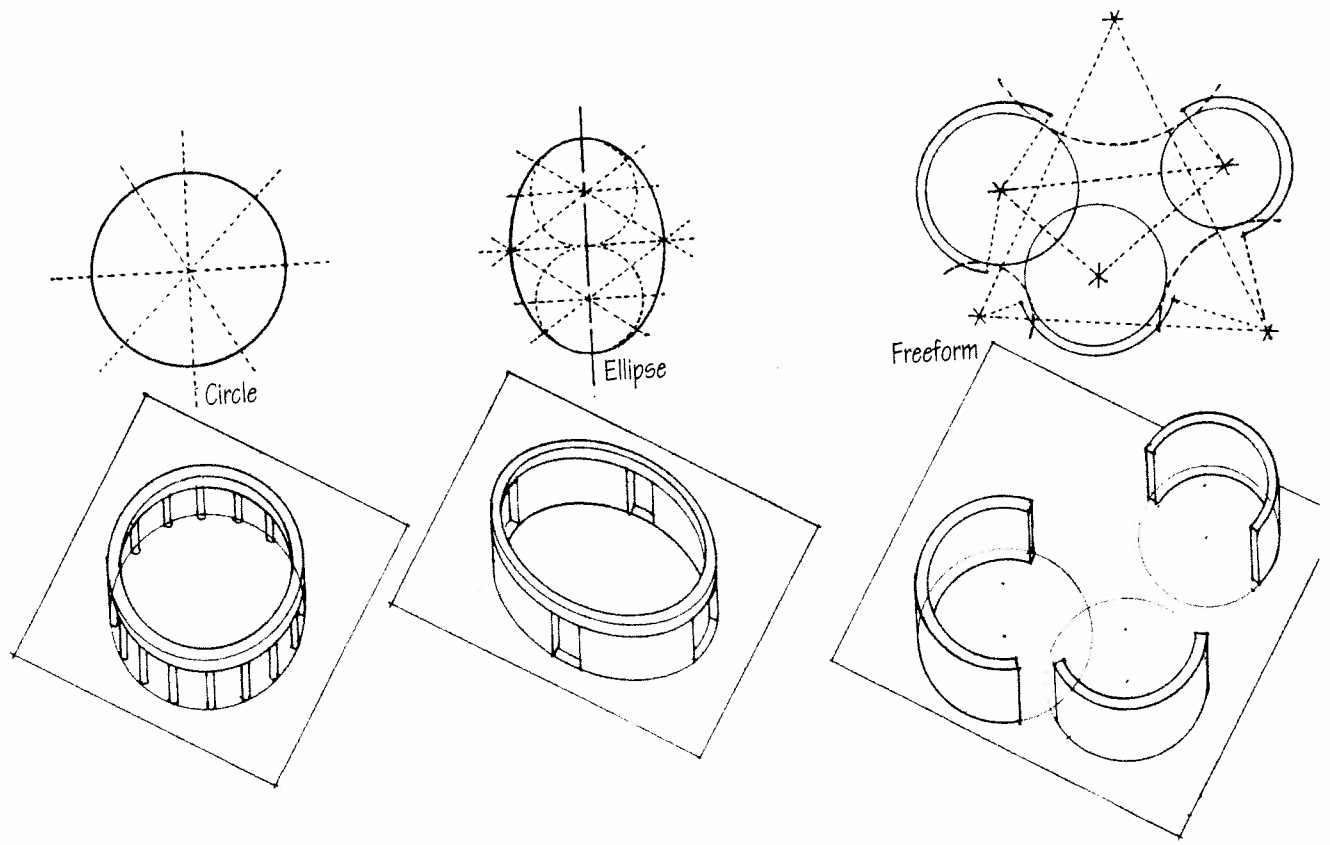

Within a rectilinear context, a curvilinear space is highly visible. Its contrasting geometry can be used to express the importance or uniqueness of its function. It can define a freestanding volume within a larger space. It can serve as a central space about which other rooms are gathered. It can articulate the edge of a space and reflect an exterior condition of the building site.

Curved walls are dynamic and visually active, leading our eyes along their curvature. The concave aspect of a curved wall encloses and focuses space inward, while its convex aspect pushes space outward.

An important consideration when dealing with a curvilinear space is the integration of furniture and other interior elements into its volume. One way of resolving conflicting geometries is to arrange interior forms as freestanding objects within the curvilinear space. Another is to integrate the form of built-in furniture and fixtures with the curved boundaries of the space.

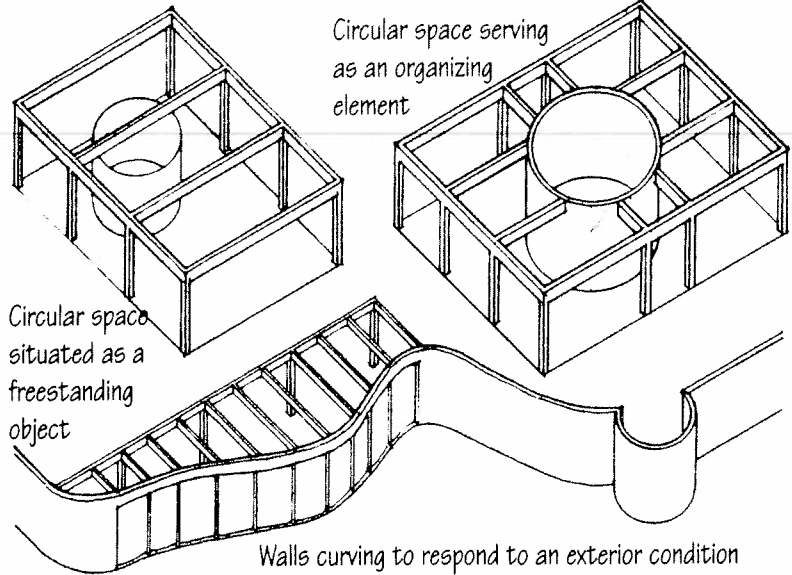

Circular space situated as a freestanding object

Circular space serving as an organizing element

Walls curving to respond to an exterior condition

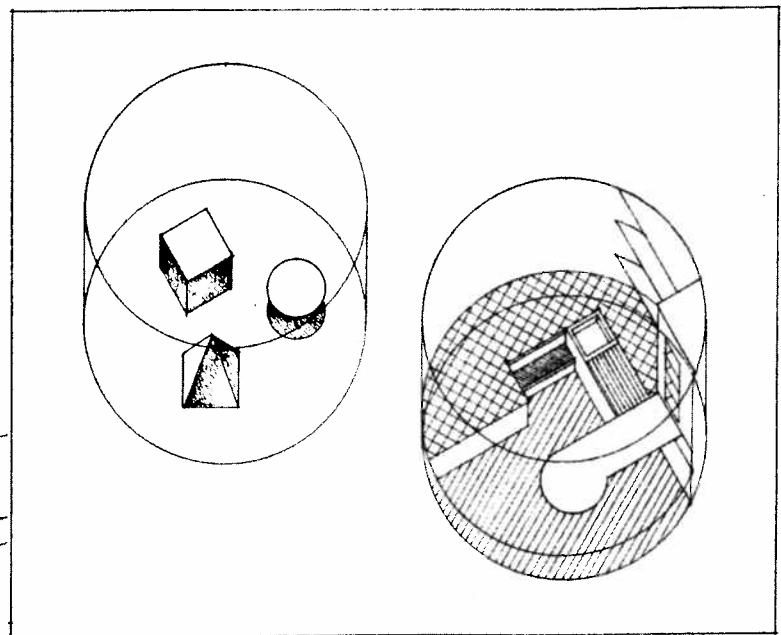

Furnishings may be placed as freestanding objects within a curvilinear space or be integrated within the curved forms.

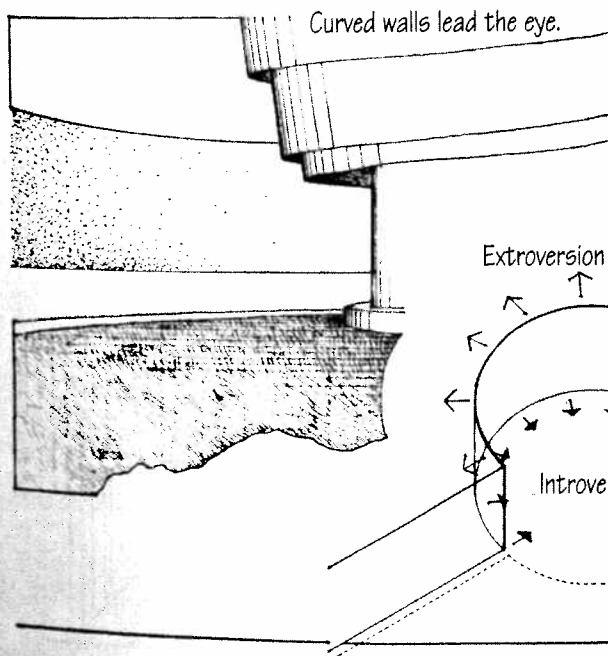

THE VERTICAL DIMENSION OF SPACE

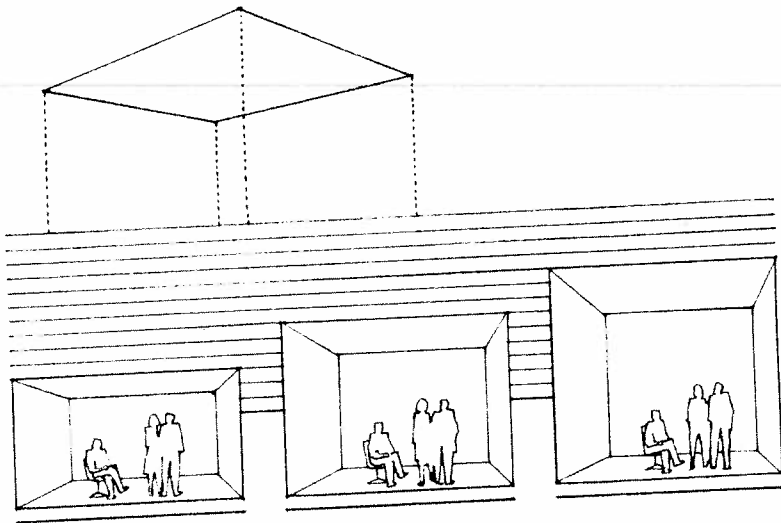

The third dimension of interior space, its height, is established by the ceiling plane. This vertical dimension is as influential as the horizontal dimensions of space in forming the spatial quality of a room.

While our perception of a room's horizontal dimensions is often distorted by the foreshortening of perspective, we can more accurately sense the relationship between the height of a space and our own body height. A measurable change in the height of a ceiling seems to have a greater effect on our impression of a space than a similar change in its width or length.

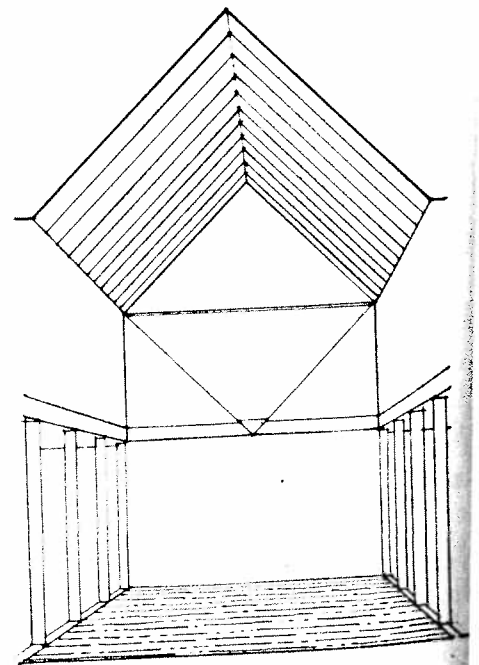
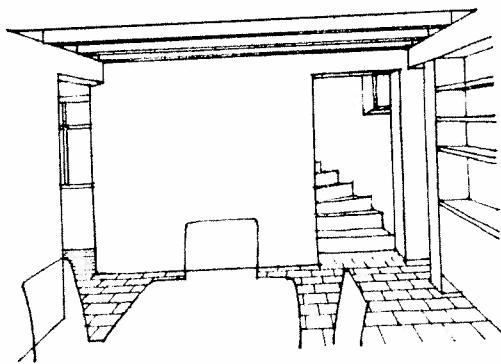
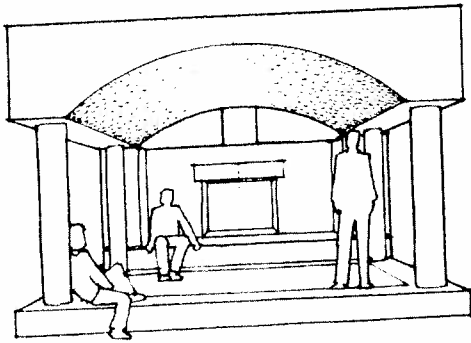

Varying the ceiling height can have a powerful effect on the perceived scale of a space.

High ceilings are often associated with feelings of loftiness or grandeur. Low ceilings often connote cave-like coziness and intimacy. Our perception of the scale of a space, however, is affected not by the height of the ceiling alone but by its relationship to the width and length of the space.

A ceiling defined by a floor plane above is typically flat. A ceiling created by a roof structure can reflect its form and the manner in which it spans the space. Shed, gable, and vaulted ceiling forms give direction to space, while domed and pyramidal ceilings emphasize the center of a space.

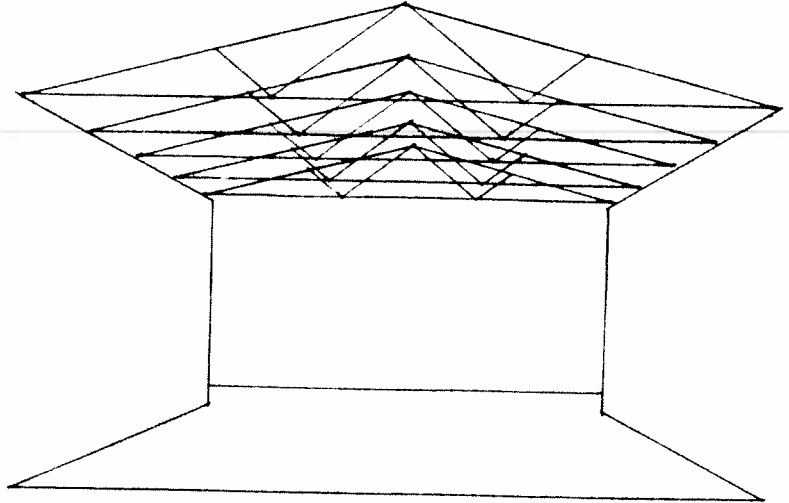

The roof structure can sometimes be left exposed, giving texture, pattern, and depth to the ceiling plane.

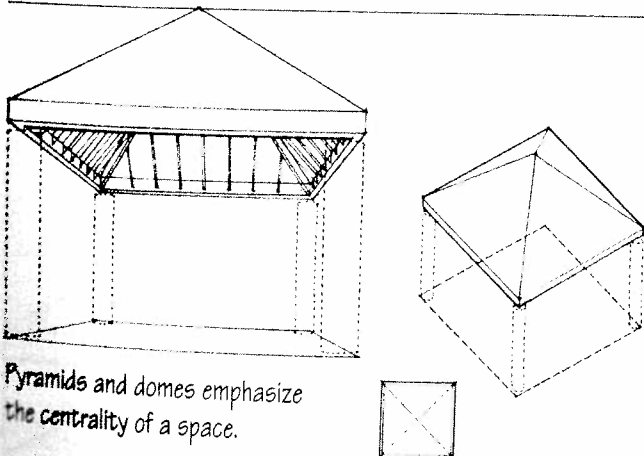
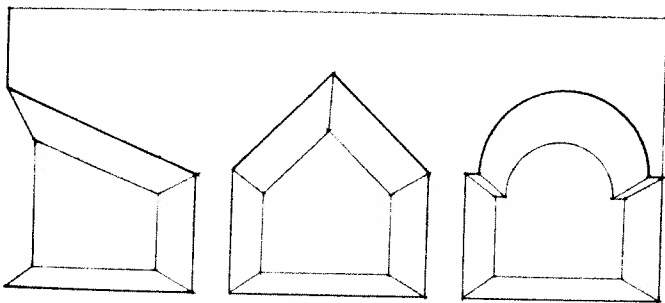

Pyramids and domes emphasize the centrality of a space.

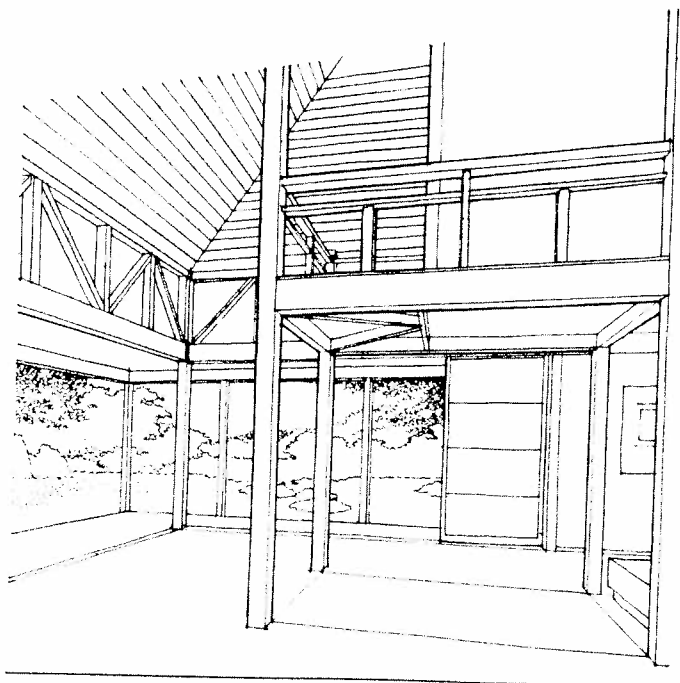

SPATIAL TRANSITIONS

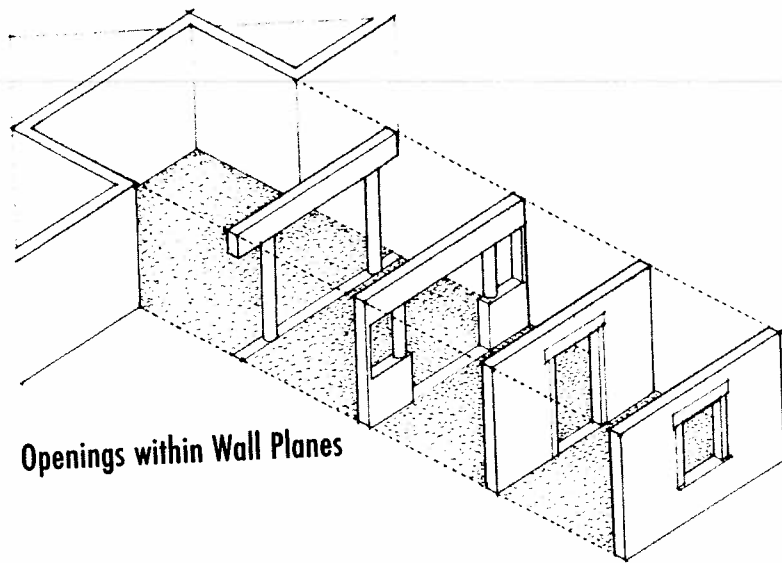

Openings within Wall Planes

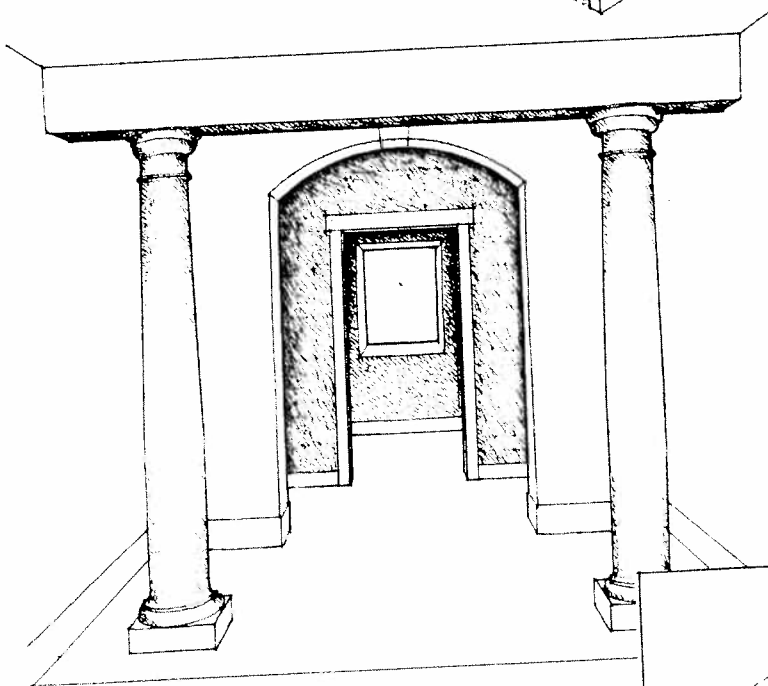

Although individual spaces may be designed and formed for a certain purpose or to house certain activities, they are gathered together within a building's enclosure because they are functionally related to one another, they are used by a common group of people, or they share a common purpose. How interior spaces are related to one another is determined not only by their relative position in a building's spatial pattern but also by the nature of the spaces that connect them and the boundaries they have in common.

Floor, wall, and ceiling planes serve to define and isolate a portion of space. Of these, the wall plane, being perpendicular to our normal line of sight, has the greatest effect as a spatial boundary. It limits our visual field and serves as a barrier to our movement. Openings created within the wall plane for windows and doorways reestablish contact with the surrounding spaces from which the room was originally cut.

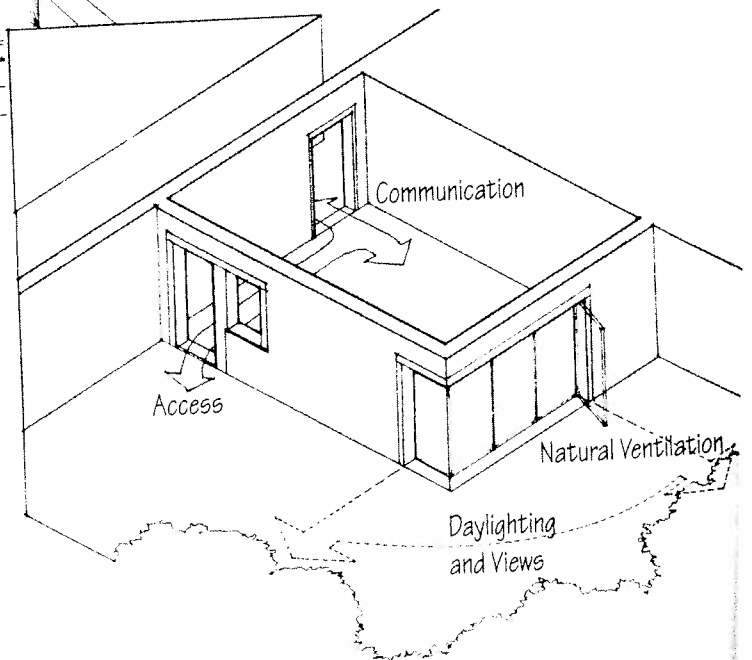

Doorways provide physical access from one space to another. When closed, they shut a room off from adjacent spaces. When open, they establish visual, spatial, and acoustical links between spaces. Large open doorways erode the integrity of a room's enclosure and strengthen its connection with adjacent spaces or the outdoors.

The thickness of the wall separating two spaces is exposed at a doorway. This depth determines the degree of separation we sense as we pass through the doorway from one space to another. The scale and treatment of the doorway itself can also provide a visual clue to the nature of the space being entered.

The number and location of doorways along a room's perimeter affects our pattern of movement within the space and how we may arrange its furnishings and organize our activities.

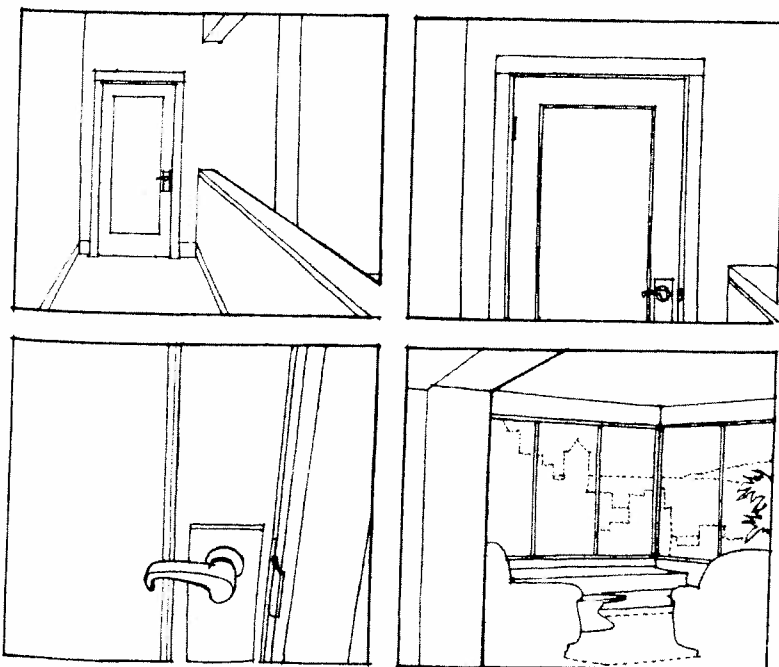
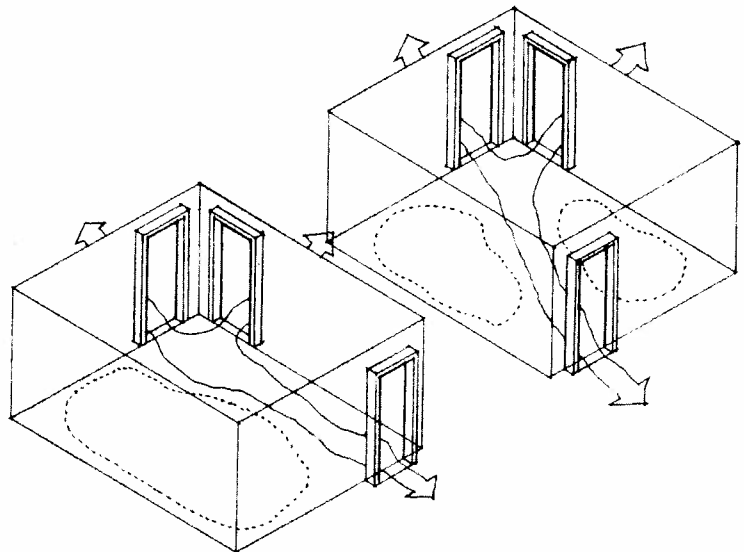
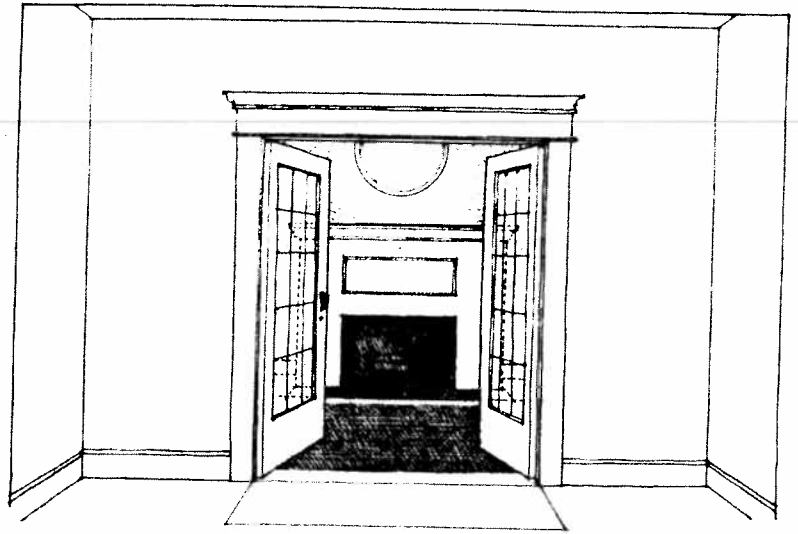

Doorway locations affect our patterns of movement and activities within a room.

WINDOWS

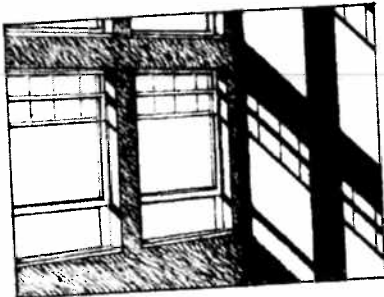

Daylighting

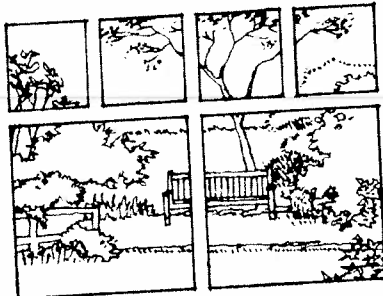

Framing Views

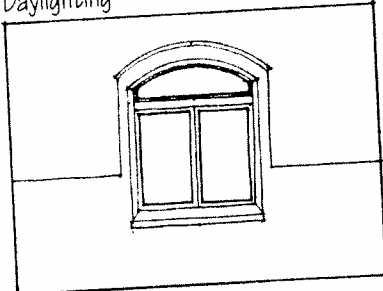

Degree of Enclosure

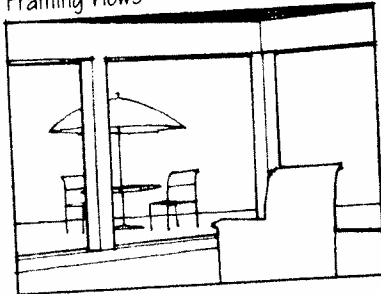

...or Transparency

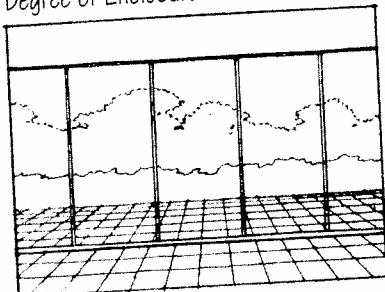

Thin Frame

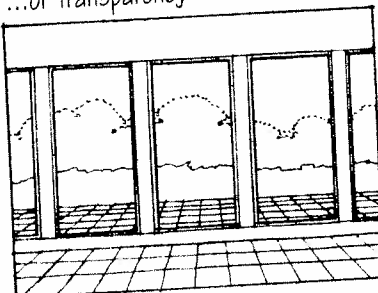

Thick Frame

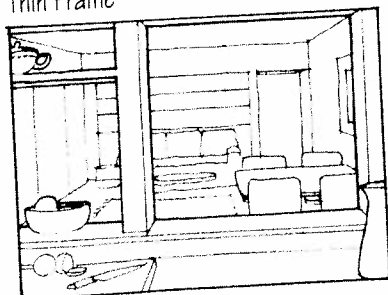

Interior Windows

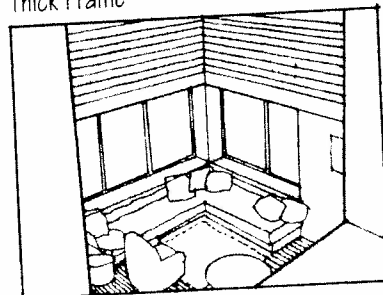

...Connecting Spaces

Windows let light and air into the interior spaces of buildings and provide views of the outdoors or from one space to another. Their size and placement, relative to the wall plane in which they occur, also affect the degree of separation between an interior space and the exterior environment.

Windows framed within a wall plane attract our attention with their brightness and outlook but maintain the enclosure provided by the wall. Large windows and glass walls attempt, at least visually, to merge indoor and outdoor space. The visual treatment of the window frames in each case can either emphasize or minimize the perceived limits of interior space.

Interior windows can, in a similar manner, visually expand a room beyond its physical boundaries and allow it to become an integral part of the surrounding interior space.

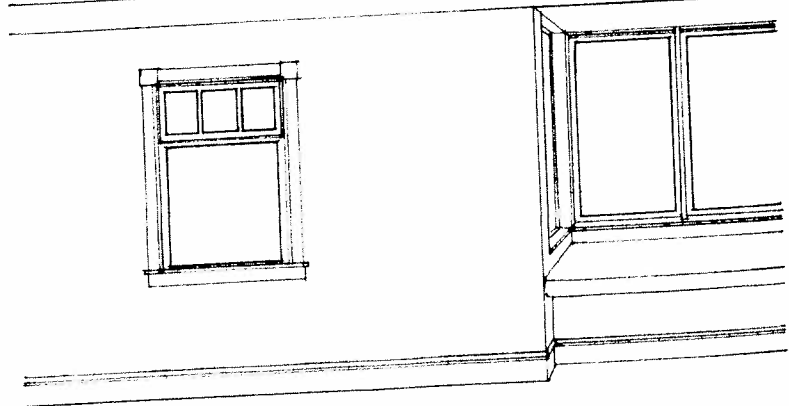
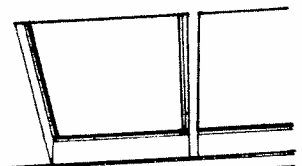

Stairways are also important forms of spatial transitions between rooms. An exterior set of steps leading to a building's entrance can serve to separate private domain from public passage and enhance the act of entry into a transitional space like a porch or terrace.

Interior stairways connect the various levels of a building. The manner in which they perform this function shapes our movement in space—how we approach a stairway, the pace and style of our ascent and descent, and what we have an opportunity to do along the way. Wide, shallow steps can serve as an invitation, while a narrow, steep stairway can lead to more private places. Landings that interrupt a flight of steps can allow a stairway to change direction and give us room for pause, rest, and outlook.

The space a stairway occupies can be considerable, but its form can be fit into an interior in several ways. It can fill and provide a focus for a space, run along one of its edges, or wrap around a room. It can be woven into the boundaries of a space or be extended into a series of terraces.

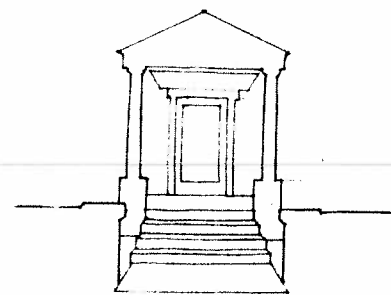

Exterior Entrances

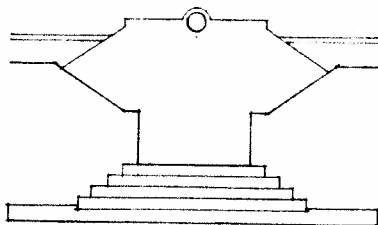

Public Approach

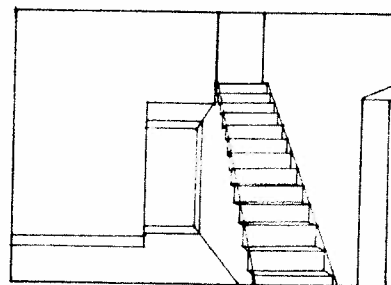

Private Access

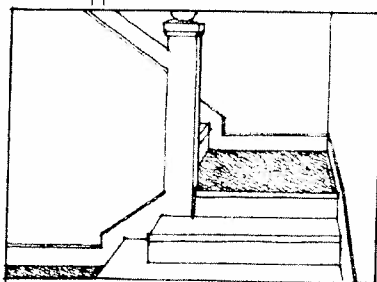

Inviting Landings

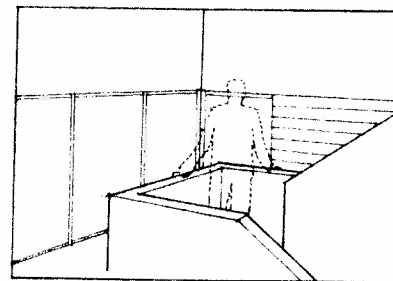

Overlooks

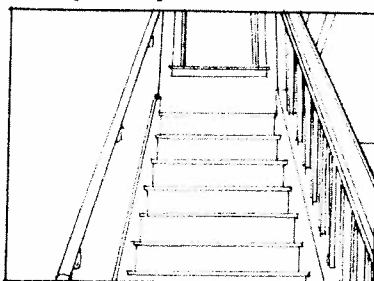

Ascent

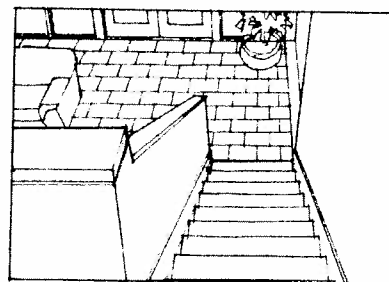

Descent

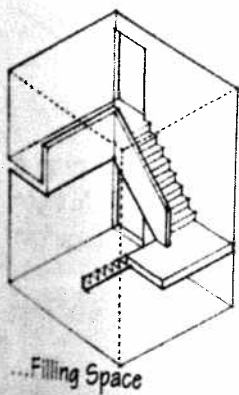

...Filling Space

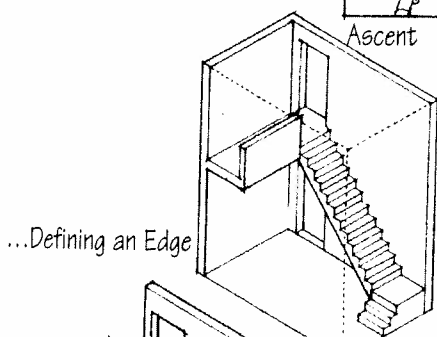

...Defining an Edge

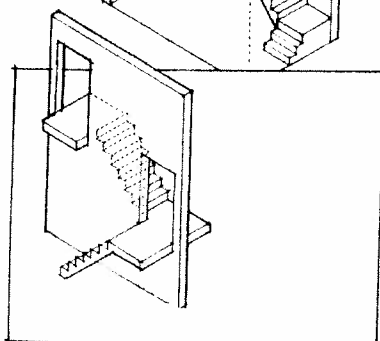

...as Sculpture

Stairways

MODIFYING SPACE

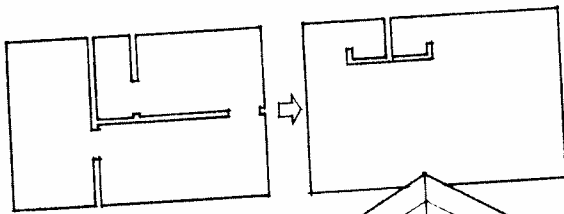
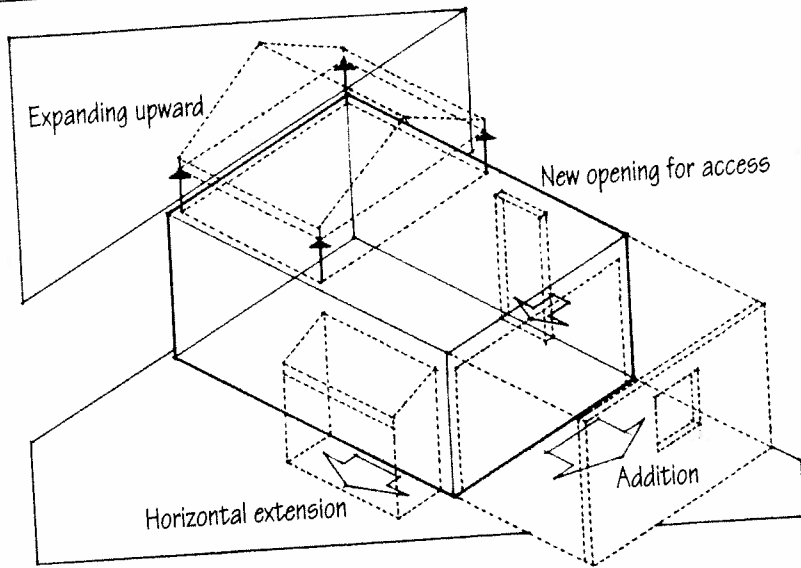

Rearranging Space

Reconfiguring an existing space requires removing walls and constructing new ones.

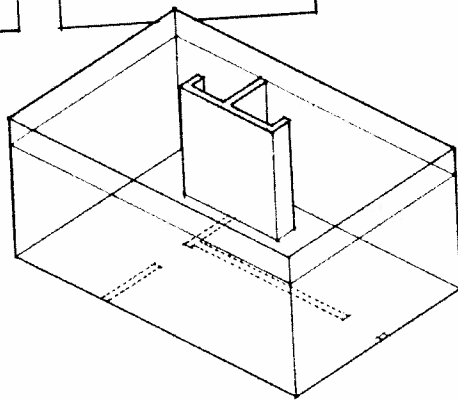

Existing framing extended

Adding New Space

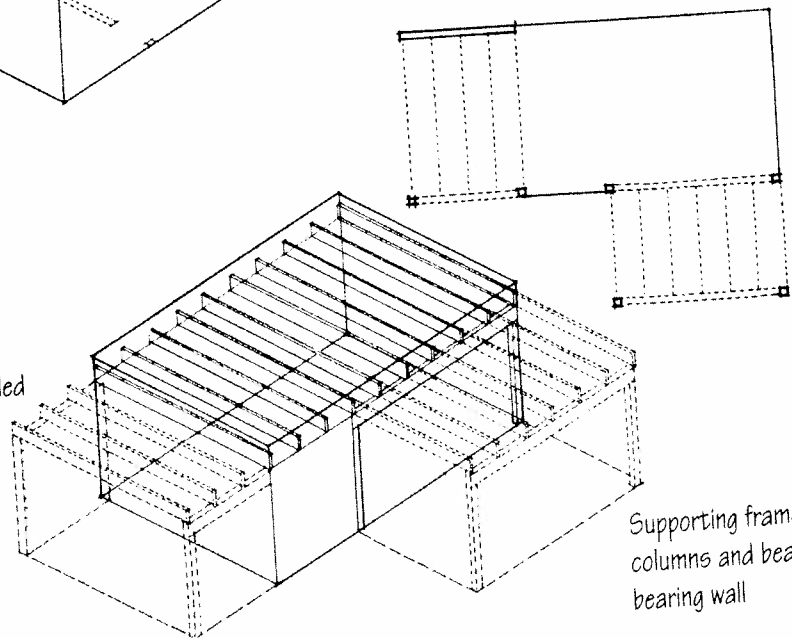

The architectural planning and design for a new building takes into account the nature of the activities to be housed; the spatial requirements for form, scale, and light; and the desired relationships among the various interior spaces. When an existing building is to be used for activities other than those for which it was originally intended, however, activity requirements must be matched with the existing conditions. Where a misfit occurs, a modification of the existing spaces may be required.

Two major types of alteration can be considered. The first involves structural changes in the boundaries of interior space and is of a more permanent nature than the second. The second type of alteration involves nonstructural modifications and enhancement accomplished through interior design.

A structural change may involve removing or adding walls to alter the shape and rearrange the pattern of existing spaces or to add on new space. When making such alterations, it is extremely important to understand the distinction between load-bearing walls and nonload-bearing partitions. It is, therefore, always advisable to consult a professional engineer or architect when making structural changes to a space.

Supporting framework of columns and beams or a bearing wall

MODIFYING SPACE

Within the boundaries of space, the existing pattern of openings can also be altered. Windows may be enlarged or added for better daylighting or to take advantage of a view. A doorway may be moved or added for better access to a room or to improve the movement paths within the space. A large doorway may be created to merge two adjacent spaces. Any new or enlarged opening in a load-bearing wall requires a lintel or header sized to carry the wall load above the opening.

To add a stairway, daylight a space with skylights, or create a vertical relationship between two levels of space, structural changes in the floor or ceiling plane are required. Alterations in these horizontal structures of a building require that the edges of any new openings be reinforced and supported by a system of beams, columns, posts, or bearing walls.

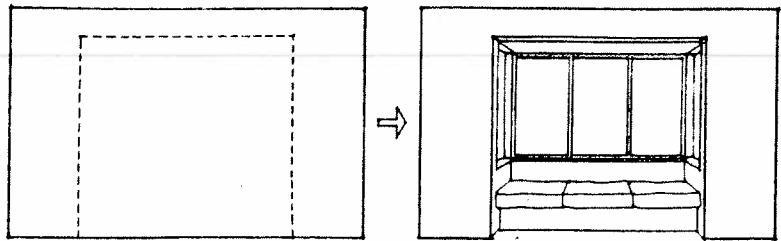

Extending space outward

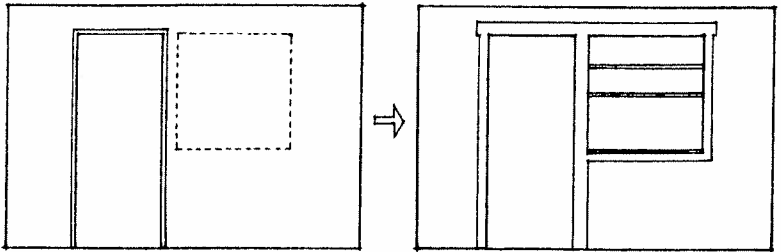

Enlarging an existing opening

New Wall Openings

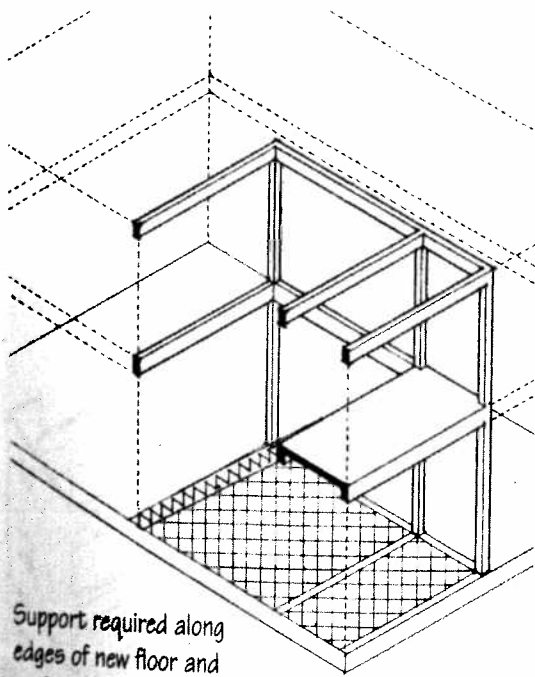
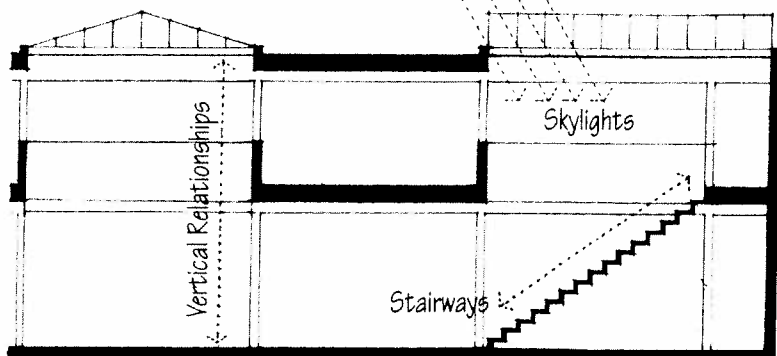
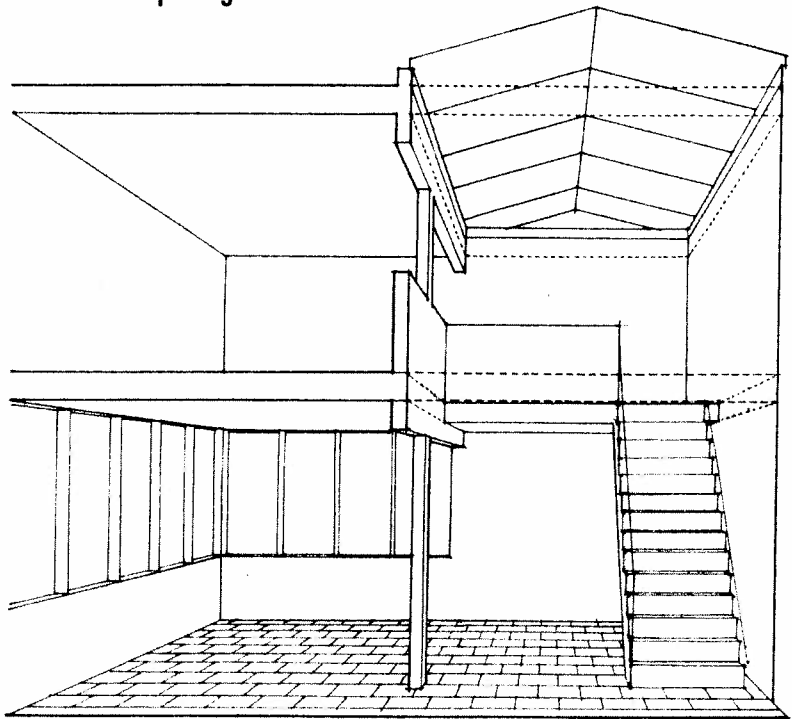

Support required along edges of new floor and roof openings.

Vertical Expansion

INTERIOR DESIGN

Even as we deal with specific design issues and with different aspects of a building's interior spaces, we should be mindful of the overall structure and patterns of the architecture. In particular, any changes in the physical boundaries of a space must be carefully planned so that the structural integrity of a building is not adversely disturbed. Major structural changes in a space, therefore, require the assistance of a professional engineer or architect.

Interior spaces can, however, also be modified and enhanced with nonstructural alterations. While structural changes alter the physical boundaries of space, nonstructural alterations are based on how we perceive, use, and inhabit space. These are the types of changes commonly planned and executed by interior designers.

